



## Electric four wheel counterbalance forklift truck

**CBM 2.5–3.5**

Lift height: 3000-4500 mm / Load capacity: 3000-3500 kg



# CBM 2.5–3.5

## Trucks that simply work.

### Built for use in changing environments.

The AntOn by Jungheinrich CBM electric forklift truck combines everything that matters in demanding daily operation: robust technology, easy handling and reliable performance.

Whether in the warehouse, outdoors or at the loading ramp: the CBM is versatile and delivers exactly where it is needed. This electric forklift truck will always make your job easier – from internal transport, manoeuvrable applications in confined spaces and the rapid loading and unloading of HGVs. It excels not only in daily use but also through its fast availability and a price/performance ratio that makes transitioning to electromobility particularly appealing.

With modern lithium-ion power, the CBM provides exactly the flexibility your business needs today – making it an easy choice: a truck that simply works.

### All benefits at a glance

- Reliable technology for everyday use.
- Robust design to meet a wide range of requirements.
- Simple operation for comfortable handling.
- Lithium-ion technology for rapid charging and consistent performance.
- High availability for fast delivery.

#### Versatile

Functional power for every job.

- Various capacity options, to match different applications, needs and budgets.
- Super-elastic (SE) tyres, solid rubber tyres or abrasion-resistant tyres.
- Compact and highly manoeuvrable – even in tight spaces.
- Large tyres and high ground clearance for outdoor use on uneven ground.
- Charging with an external charger.

#### Straightforward

Intuitive technology that makes work easier.

- LED display with all key information at a glance.
- Simple control elements – from the control panel and comfortable pedal to the water-resistant charging port.
- Optimum visibility for safer daily operation.
- Ergonomic operator position, adjustable steering wheel and generous legroom.

#### Cost-effective

Solutions for every task and every budget.

- Maintenance-free 80-V lithium-ion battery for long service life and short charging pauses.
- Rapid lift speeds save time with every application.
- High availability and cost-efficient acquisition.
- Fast spare parts supply keeps your operations running smoothly.

## VDI table (CBM 2.5)

Characteristic	1.1	Manufacturer (abbreviated description)		Jungheinrich
	1.2	Manufacturer's type designation		CBM 2.5-3.5
	1.3	Drive		Electric
	1.4	Operation		Seat
	1.5	Load capacity/load	Q kg	2500
	1.6	Load centre distance	c mm	500
	1.8	Load distance, centre of drive axle to fork	x mm	495
	1.9	Wheelbase	y mm	1685
	Weights	2.1.1	Service weight (incl. battery)	kg
2.2		Axle load laden front/rear	kg	5679 / 668
2.3		Axle load unladen front/rear	kg	1711 / 2136
Wheels/suspension system	3.1	Tyres		Super-elastic (SE)
	3.2	Tyre size, front		7.00-12-12PR
	3.3	Tyre size, rear		18X7-8-14PR
	3.5	Wheels, number front/back (x=driven)		2x / 2
	3.6	Tread width, front	b10 mm	975
	3.7	Tread width, rear	b11 mm	955
	Basic dimensions	4.2	Retracted mast height (h1)	h1 mm
4.3		Free lift (h2)	h2 mm	195
4.4		Lift (h3)	h3 mm	3000
4.5		Extended mast height (h4)	h4 mm	4065
4.7		Height of overhead guard (cab)	h6 mm	2165
4.8		Seat height/stand height	h7 mm	1095
4.12		Coupling height	h10 mm	280
4.19		total length	l1 mm	3605
4.20		Length including fork shank	l2 mm	2535
4.21.1		total width	b1 mm	1154
4.22		Fork dimensions	s/e/l mm	40 x 122 x 1150
4.23		Fork carriage connection class		2A
4.24		Fork carriage width	b3 mm	1040
4.31		Ground clearance laden under mast	m1 mm	100
4.32		Ground clearance centre of wheelbase	m2 mm	150
4.34.1		Aisle width (pallet 1000x1200 sideways)	Ast mm	3979
4.34.2		Aisle width (pallet 800x1200 length)	Ast mm	4179
4.35		Turning radius	Wa mm	2284
4.36	Smallest pivot point distance	b13 mm	838	
Performance data	5.1	Travel speed laden/unladen	km/h	16 / 17
	5.2	Lift speed laden/unladen	m/s	0.38 / 0.45
	5.3	Lowering speed laden/unladen	m/s	0.45 / 0.52
	5.5	Drawbar pull laden/unladen	N	2110 / 2110
	5.6	Max. drawbar pull laden/unladen	N	15925 / 15925
	5.8	Max. gradeability laden/unladen	%	17 / 25
	5.10	Service brake		hydraulic

E-motor/Electronics	6.1	Drive motor, performance S2 60 min	kW	16
	6.2	Lift motor, performance with S3	kW	24
	6.4	Battery voltage/nominal capacity	V / Ah	80 / 280
	6.6.1	Energy consumption according to EN cycle	kWh/h	7.7
	6.6.2	CO2 equivalent according to EN ISO 23308	kg/h0	4.2
	6.7	Throughput	t/h	155
	6.8	Turnover efficiency according to VDI 2198	t/kWh	6.85
	Other	8.1	Type of drive control	
10.1		Operating pressure for attachment	bar	180
10.2		Oil flow for attachments	l/min	35
10.7		Sound pressure level according to EN12053	dB (A)	74

- This data sheet according to VDI guideline 2198 only states the technical values of the standard truck. Different tyres, other masts, additional equipment etc. may result in different values.

## VDI table (CBM 3.0)

Characteristic	1.1	Manufacturer (abbreviated description)		Jungheinrich
	1.2	Manufacturer's type designation		CBM 2.5-3.5
	1.3	Drive		Electric
	1.4	Operation		Seat
	1.5	Load capacity/load	Q kg	3000
	1.6	Load centre distance	c mm	500
	1.8	Load distance, centre of drive axle to fork	x mm	481
	1.9	Wheelbase	y mm	1760
	Weights	2.1.1	Service weight (incl. battery)	kg
2.2		Axle load laden front/rear	kg	6510 / 1304
2.3		Axle load unladen front/rear	kg	1835 / 1979
Wheels/suspension system	3.1	Tyres		Super-elastic (SE)
	3.2	Tyre size, front		28X9-15-14PR
	3.3	Tyre size, rear		6.50-10-10PR
	3.5	Wheels, number front/back (x=driven)		2x / 2
	3.6	Tread width, front	b10 mm	1010
	3.7	Tread width, rear	b11 mm	980
	Basic dimensions	4.2	Retracted mast height (h1)	h1 mm
4.3		Free lift (h2)	h2 mm	135
4.4		Lift (h3)	h3 mm	3000
4.5		Extended mast height (h4)	h4 mm	4130
4.7		Height of overhead guard (cab)	h6 mm	2160
4.8		Seat height/stand height	h7 mm	1095
4.12		Coupling height	h10 mm	273
4.19		total length	l1 mm	3750
4.20		Length including fork shank	l2 mm	2680
4.21.1		total width	b1 mm	1230
4.22		Fork dimensions	s/e/l mm	45 x 122 x 1150
4.23		Fork carriage connection class		3A
4.24		Fork carriage width	b3 mm	1100
4.31		Ground clearance laden under mast	m1 mm	120
4.32		Ground clearance centre of wheelbase	m2 mm	150
4.34.1		Aisle width (pallet 1000x1200 sideways)	Ast mm	4166
4.34.2		Aisle width (pallet 800x1200 length)	Ast mm	4366
4.35		Turning radius	Wa mm	2485
4.36		Smallest pivot point distance	b13 mm	838
Performance data	5.1	Travel speed laden/unladen	km/h	16 / 17
	5.2	Lift speed laden/unladen	m/s	0.45 / 0.55
	5.3	Lowering speed laden/unladen	m/s	0.5 / 0.44
	5.5	Drawbar pull laden/unladen	N	2618 / 2618
	5.6	Max. drawbar pull laden/unladen	N	24852 / 24852
	5.8	Max. gradeability laden/unladen	%	20 / 25
	5.10	Service brake		hydraulic

E-motor/Electronics	6.1	Drive motor, performance S2 60 min	kW	16
	6.2	Lift motor, performance with S3	kW	30
	6.4	Battery voltage/nominal capacity	V / Ah	80 / 280
	6.6.1	Energy consumption according to EN cycle	kWh/h	8.26
	6.6.2	CO2 equivalent according to EN ISO 23308	kg/h0	4.5
	6.7	Throughput	t/h	180
	6.8	Turnover efficiency according to VDI 2198	t/kWh	7.7
	Other	8.1	Type of drive control	
10.1		Operating pressure for attachment	bar	180
10.2		Oil flow for attachments	l/min	35
10.7		Sound pressure level according to EN12053	dB (A)	74

- This data sheet according to VDI guideline 2198 only states the technical values of the standard truck. Different tyres, other masts, additional equipment etc. may result in different values.

## VDI table (CBM 3.5)

Characteristic	1.1	Manufacturer (abbreviated description)		Jungheinrich
	1.2	Manufacturer's type designation		CBM 2.5-3.5
	1.3	Drive		Electric
	1.4	Operation		Seat
	1.5	Load capacity/load	Q kg	3500
	1.6	Load centre distance	c mm	500
	1.8	Load distance, centre of drive axle to fork	x mm	486
	1.9	Wheelbase	y mm	1760
	Weights	2.1.1	Service weight (incl. battery)	kg
2.2		Axle load laden front/rear	kg	7290 / 1237
2.3		Axle load unladen front/rear	kg	1810 / 3217
Wheels/suspension system	3.1	Tyres		Super-elastic (SE)
	3.2	Tyre size, front		28X9-15-14PR
	3.3	Tyre size, rear		6.50-10-10PR
	3.5	Wheels, number front/back (x=driven)		2x / 2
	3.6	Tread width, front	b10 mm	1010
	3.7	Tread width, rear	b11 mm	980
	Basic dimensions	4.2	Retracted mast height (h1)	h1 mm
4.3		Free lift (h2)	h2 mm	135
4.4		Lift (h3)	h3 mm	3000
4.5		Extended mast height (h4)	h4 mm	4130
4.7		Height of overhead guard (cab)	h6 mm	2160
4.8		Seat height/stand height	h7 mm	1095
4.12		Coupling height	h10 mm	273
4.19		total length	l1 mm	3798
4.20		Length including fork shank	l2 mm	2728
4.21.1		total width	b1 mm	1230
4.22		Fork dimensions	s/e/l mm	50 x 122 x 1150
4.23		Fork carriage connection class		3A
4.24		Fork carriage width	b3 mm	1100
4.31		Ground clearance laden under mast	m1 mm	120
4.32		Ground clearance centre of wheelbase	m2 mm	150
4.34.1		Aisle width (pallet 1000x1200 sideways)	Ast mm	4210
4.34.2		Aisle width (pallet 800x1200 length)	Ast mm	4410
4.35		Turning radius	Wa mm	2524
4.36	Smallest pivot point distance	b13 mm	838	
Performance data	5.1	Travel speed laden/unladen	km/h	16 / 17
	5.2	Lift speed laden/unladen	m/s	0.44 / 0.55
	5.3	Lowering speed laden/unladen	m/s	0.5 / 0.44
	5.5	Drawbar pull laden/unladen	N	2842 / 2842
	5.6	Max. drawbar pull laden/unladen	N	24852 / 24852
	5.8	Max. gradeability laden/unladen	%	17 / 25
	5.10	Service brake		hydraulic

E-motor/Electronics	6.1	Drive motor, performance S2 60 min	kW	16
	6.2	Lift motor, performance with S3	kW	30
	6.4	Battery voltage/nominal capacity	V / Ah	80 / 280
	6.6.1	Energy consumption according to EN cycle	kWh/h	9.06
	6.6.2	CO2 equivalent according to EN ISO 23308	kg/h0	4.9
	6.7	Throughput	t/h	210
	6.8	Turnover efficiency according to VDI 2198	t/kWh	7.1
Other	8.1	Type of drive control		AC
	10.1	Operating pressure for attachment	bar	180
	10.2	Oil flow for attachments	l/min	35
	10.7	Sound pressure level according to EN12053	dB (A)	74

- This data sheet according to VDI guideline 2198 only states the technical values of the standard truck. Different tyres, other masts, additional equipment etc. may result in different values.

# Appendix

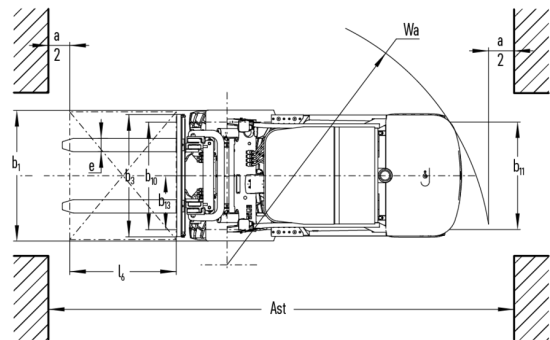
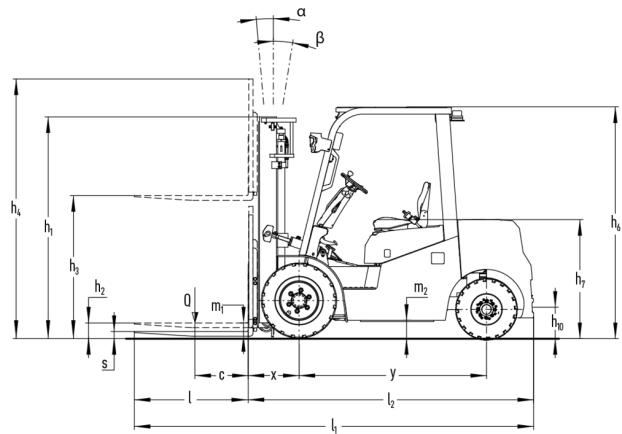
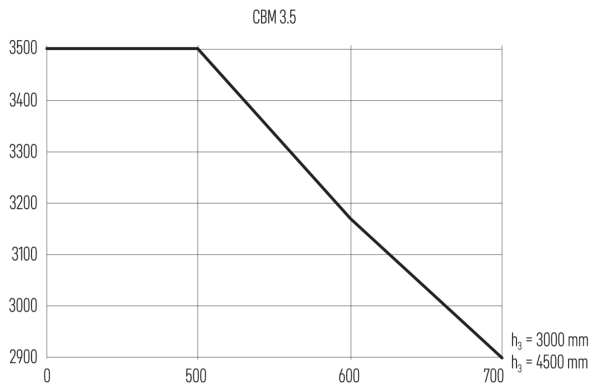
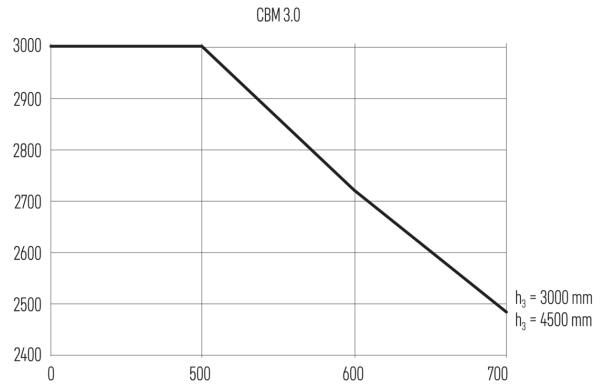
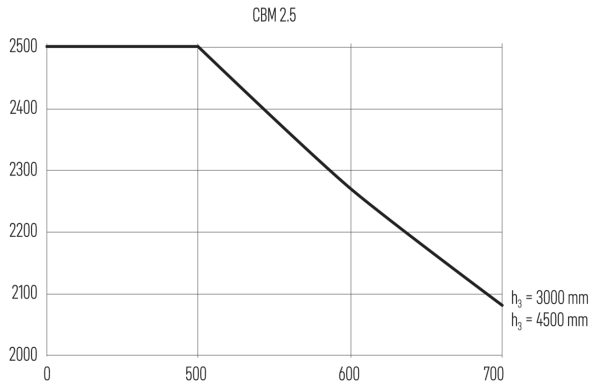

The German production facilities in  
Norderstedt, Moosburg and Landsberg are  
certified as well as our Genuine Parts  
Center in Kaltenkirchen.

ISO 9001  
ISO 14001

Jungheinrich fork lift trucks meet European  
safety requirements.



**anton**  
BY JUNGHEINRICH