



## Electric pedestrian pallet truck

### PTL 1.5

Lift height: 105 mm / Load capacity: 1500 kg



# PTL 1.5

## A pallet truck for every situation.

### Ideal for use in warehouses, outdoors or on HGVs.

The AntOn by Jungheinrich PTL 1.5 is an entry-level model that has everything you need for your daily work – the electric pallet truck is compact and easy to operate.

In the warehouse, at the shop or on the HGV: the PTL 1.5 adapts flexibly to a wide range of tasks – doing exactly what you expect of it.

Equipped with modern lithium-ion technology, well-thought-out functions and selectable fork lengths, it will swiftly become a reliable all-rounder. If you require longer operating times, the PTL 1.5 can be equipped with a second removable battery for additional power.

Designed for robust and reliable daily operation, it impresses with both its performance and its short delivery times. And all this at a price that makes it a smart choice for every situation – whether for newcomers or as an addition to your existing fleet.

### All benefits at a glance

- Entry-level model with strong base functionality.
- Lithium-ion technology for rapid charging and consistent performance.
- High spare parts availability provides reduced downtime.
- Always robust, reliable and flexible.
- Quickly available to meet urgent demand.

#### Versatile

One truck for every task – maximum flexibility.

- The perfect addition for various transport jobs with different fork widths.
- Equipment options for special requirements: stabilising wheels for more safety over uneven ground. Second battery socket for greater availability.
- Compact design – ideal for use on HGVs and precise manoeuvring in confined spaces.

#### Straightforward

Built for function and simplicity.

- Easy to use and handle – suitable for all staff.
- External charger for rapid booster charging.
- Effortless battery exchange thanks to practical plug-in system.
- Simple self-service with video guides.

#### Cost-effective

Strong performance at a smart price.

- Cost-effective to buy and operate.
- Enduring power with up to 2 x 24 V to 20 Ah removable lithium-ion batteries.
- Reduces physical strain on the operator and improves workplace efficiency.
- Robust and durable technology ensures reliable operation.
- One truck. Many applications.

# VDI table

Characteristic	1.1	Manufacturer (abbreviated description)		Jungheinrich			
	1.2	Manufacturer's type designation		PTL 1.5 (560x1,150 mm)	PTL 1.5 (685x1,150 mm)	PTL 1.5 (560x1,150 mm, support wheel)	PTL 1.5 (685x1,150 mm, support wheel)
	1.3	Drive type		electric			
	1.4	Operation		Pedestrian			
	1.5	Load capacity/load	Q kg	1500			
	1.6	Load centre distance	c mm	600			
	1.8	Load distance, centre of drive axle to fork	x mm	950			
	1.9	Wheelbase	y mm	1180			
	Weights	2.1.1	Service weight (incl. battery)	kg	112	115	117
2.2		Axle load laden front/rear	kg	477 / 1135	478 / 1137	477 / 1135	478 / 1137
2.3		Axle load unladen front/rear	kg	84 / 28	86 / 29	84 / 28	86 / 29
Wheels/chassis	3.1	Tyres		Polyurethane (PU)			
	3.2	Tyre size, front		Ø210 x 70			
	3.3	Tyre size, rear		Ø80 x 61			
	3.4	Additional wheels		-		Ø74 x 30	
	3.5	Wheels, number front/back (x=driven)		1x + - / 4		1x + 2 / 4	
	3.7	Tread width, rear	b11 mm	410	535	410	535
Basic dimensions	4.4	Lift (h3)	h3 mm	105			
	4.9	Height of tiller handle in drive position min./max.	h14 mm	645 / 1145			
	4.15	Height, lowered	h13 mm	82			
	4.19	Total length	l1 mm	1550			
	4.20	Length including fork shank	l2 mm	400			
	4.21.1	total width	b1 mm	590	695	590	695
	4.22	Fork dimensions	s/ e/l mm	55 x 150 x 1150			
	4.25	Width across forks	b5 mm	560	685	560	685
	4.32	Ground clearance centre of wheelbase	m2 mm	27			
	4.34.1	Aisle width (pallet 1000x1200 sideways)	Ast mm	2160			
	4.34.2	Aisle width (pallet 800x1200 length)	Ast mm	2025			
4.35	Turning radius	Wa mm	1360				
Performance data	5.1	Travel speed laden/unladen	km/h	4 / 4.5			
	5.2	Lift speed laden/unladen	m/s	0.02 / 0.02			
	5.3	Lowering speed laden/unladen	m/s	0.06 / 0.04			
	5.8	Max. gradeability laden/unladen	%	6 / 16			
	5.10	Service brake		electromagnetic			

Electric motor/electronics	6.1	Drive motor, performance S2 60 min	kW	0.75
	6.2	Lift motor, performance with S3	kW	0.5
	6.4	Battery voltage/nominal capacity	V / Ah	24 / 20
	6.5	Battery weight	kg	5
	6.6.1	Energy consumption according to EN cycle	kWh/h	0.18
	6.6.2	CO2 equivalent according to EN ISO 23308	kg/h0	0.1
	6.7	Throughput	t/h	60
	6.8	Turnover efficiency according to VDI 2198	t/kWh	333.33
Other	8.1	Type of drive control		Impulse/DC
	10.7	Sound pressure level according to EN12053	dB (A)	74

- This data sheet according to VDI guideline 2198 only states the technical values of the standard truck. Different tyres, other masts, additional equipment etc. may result in different values.

# Appendix

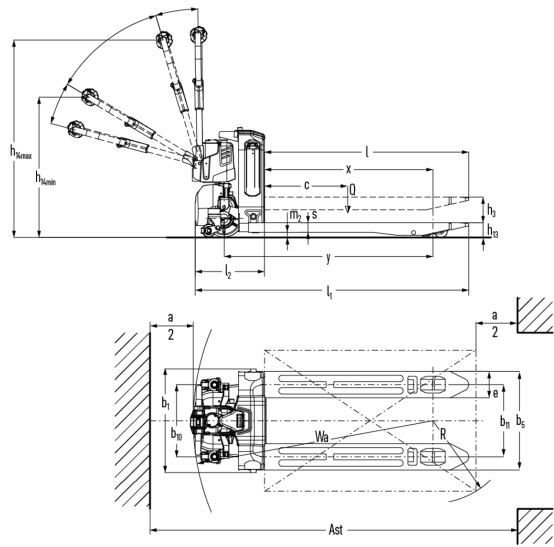
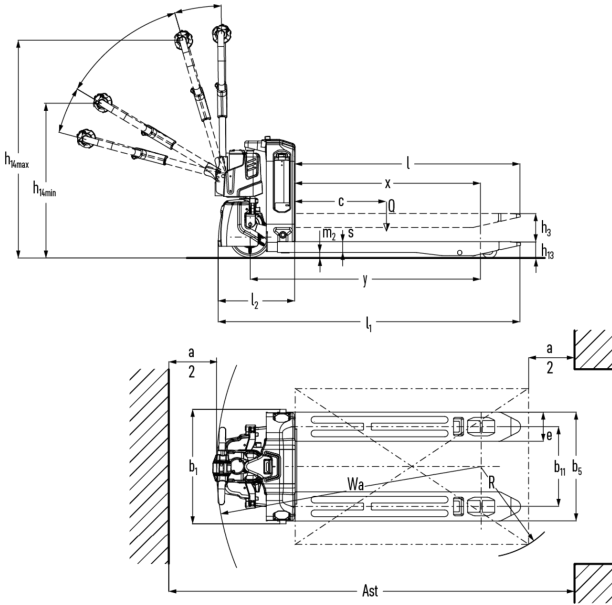
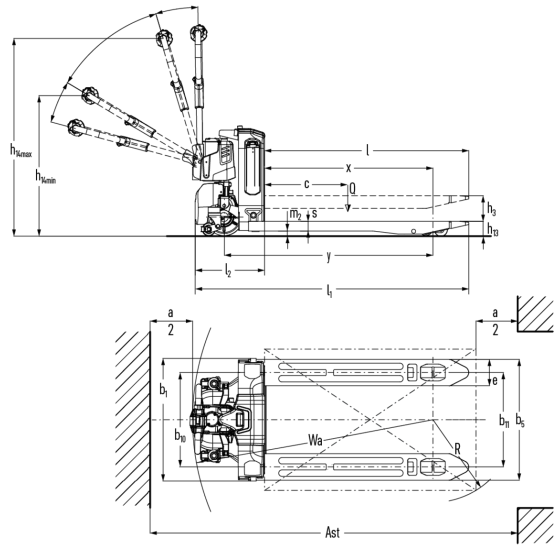
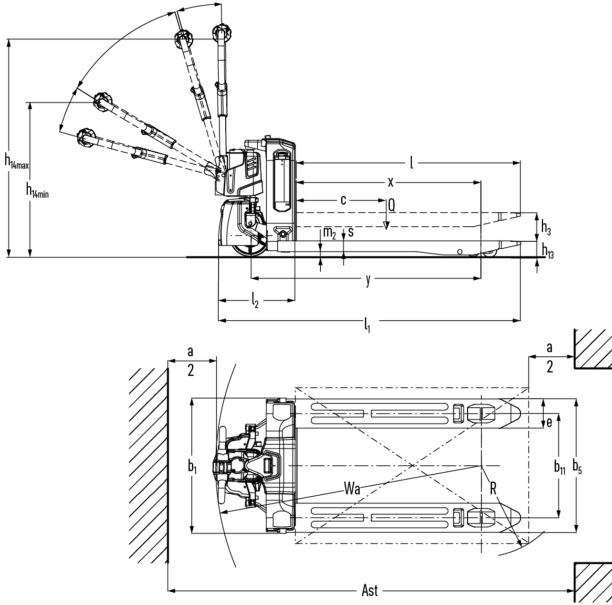

The German production facilities in  
Norderstedt, Moosburg and Landsberg are  
certified as well as our Genuine Parts  
Center in Kaltenkirchen.

ISO 9001  
ISO 14001

Jungheinrich fork lift trucks meet European  
safety requirements.



**anton**  
BY JUNGHEINRICH