



Electric four wheel counterbalance forklift truck

CBH 2.0–3.5

Lift height: 3300-4800 mm / Load capacity: 2000-3000 kg



CBH 2.0–3.5

Trucks that simply work.

Built for use in changing environments.

The AntOn by Jungheinrich CBH electric forklift truck combines what counts for daily operation: robust technology, easy handling and reliable performance.

Whether in the warehouse, outdoors or at the loading ramp: the CBH is versatile and delivers exactly where it is needed. This electric forklift truck will always make your job easier – from internal transport, manoeuvrable applications in confined spaces and the rapid loading and unloading of HGVs.

It excels not only in daily use but also through its fast availability and a price/performance ratio that makes transitioning to electromobility particularly appealing.

With three carefully designed equipment variants and advanced lithium-ion power, the CBH offers exactly the flexibility your company needs today, making the choice easy – a forklift truck that simply works.

All benefits at a glance

- Reliable technology for everyday use.
- Three equipment variants for a wide range of requirements.
- Simple operation for comfortable handling.
- Lithium-ion technology for fast charging and consistent performance.
- High availability for fast delivery.

Versatile

Functional power for every job.

- Two capacity options, each available in three equipment variants to match different applications, needs and budgets.
- Compact and highly manoeuvrable – even in tight spaces.
- Large tyres and high ground clearance for outdoor use on uneven ground.
- Flexible charging options via an external or built-in charger, depending on the model.
- Travel speeds up to 17 km/h for more efficient working.

Straightforward

Intuitive technology that makes work easier.

- LED display with all key info at a glance.
- Simple control elements – from the control panel and comfortable pedal to the water-resistant charging port.
- Optimum visibility for safer daily operation.
- Ergonomic operator position with adjustable steering wheel and, depending on the variant, comfort seat and generous legroom.

Cost-effective

Solutions for every task and every budget.

- Maintenance-free 80-V lithium-ion battery for long service life and short charging pauses.
- Rapid lift speeds save time with every application.
- High availability and cost-efficient acquisition.
- Fast spare parts supply keeps your operations running smoothly.

VDI table (CBH 2.0)

Characteristic	1.1	Manufacturer (abbreviated description)			Jungheinrich
	1.2	Manufacturer's type designation			CBH 2.0-3.5
	1.3	Drive			Electric
	1.4	Operation			Seat
	1.5	Load capacity/load	Q	kg	2000
	1.6	Load centre distance	c	mm	500
	1.8	Load distance, centre of drive axle to fork	x	mm	495
	1.9	Wheelbase	y	mm	1540
	Weights	2.1.1	Service weight (incl. battery)		kg
2.2		Axle load laden front/rear		kg	4930 / 619
2.3		Axle load unladen front/rear		kg	1635 / 1909
Wheels/suspension system	3.1	Tyres			Super-elastic (SE)
	3.2	Tyre size, front			7.00-12
	3.3	Tyre size, rear			18x7-8
	3.5	Wheels, number front/back (x=driven)			2x / 2
	3.6	Tread width, front	b10	mm	975
	3.7	Tread width, rear	b11	mm	955
	Basic dimensions	4.1	Forward/backward tilt of mast	a/β	°
4.2		Retracted mast height (h1)	h1	mm	2090
4.3		Free lift (h2)	h2	mm	120
4.4		Lift (h3)	h3	mm	3000
4.5		Extended mast height (h4)	h4	mm	4025
4.7		Height of overhead guard (cab)	h6	mm	2165
4.8		Seat height/stand height	h7	mm	1095
4.12		Coupling height	h10	mm	310
4.19		total length	l1	mm	3535
4.20		Length including fork shank	l2	mm	2385
4.21.1		total width	b1	mm	1154
4.22		Fork dimensions	s/e/l	mm	40 x 122 x 1150
4.23		Fork carriage connection class			2A
4.24		Fork carriage width	b3	mm	1040
4.31		Ground clearance laden under mast	m1	mm	125
4.32		Ground clearance centre of wheelbase	m2	mm	150
4.34.1		Aisle width (pallet 1000x1200 sideways)	Ast	mm	3824
4.34.2		Aisle width (pallet 800x1200 length)	Ast	mm	4024
4.35		Turning radius	Wa	mm	2129
4.36		Smallest pivot point distance	b13	mm	662
Performance data	5.1	Travel speed laden/unladen		km/h	14 / 15
	5.2	Lift speed laden/unladen		m/s	0.4 / 0.41
	5.3	Lowering speed laden/unladen		m/s	0.54 / 0.56
	5.5	Drawbar pull laden/unladen		N	2090 / 2090
	5.6	Max. drawbar pull laden/unladen		N	12570 / 12570
	5.7	Gradeability laden/unladen		%	7 / 14
	5.8	Max. gradeability laden/unladen		%	15 / 20
	5.9	Acceleration time laden/unladen		s	7.9 / 7.5
	5.10	Service brake			hydraulic

E-motor/Electronics	6.1	Drive motor, performance S2 60 min	kW	10
	6.2	Lift motor, performance with S3	kW	16
	6.4	Battery voltage/nominal capacity	V / Ah	80 / 230
	6.6.1	Energy consumption according to EN cycle	kWh/h	6.77
	6.6.2	CO2 equivalent according to EN ISO 23308	kg/h0	3.66
	6.7	Throughput	t/h	116
	6.8.1	Energy consumption with max. throughput	kWh/h	5.88
Other	8.1	Type of drive control		AC
	10.1	Operating pressure for attachment	bar	180
	10.2	Oil flow for attachments	l/min	35
	10.7	Sound pressure level according to EN12053	dB (A)	74

- This data sheet according to VDI guideline 2198 only states the technical values of the standard truck. Different tyres, other masts, additional equipment etc. may result in different values.

VDI table (CBH 2.5)

Characteristic	1.1	Manufacturer (abbreviated description)			Jungheinrich
	1.2	Manufacturer's type designation			CBH 2.0-3.5
	1.3	Drive			Electric
	1.4	Operation			Seat
	1.5	Load capacity/load	Q	kg	2500
	1.6	Load centre distance	c	mm	500
	1.8	Load distance, centre of drive axle to fork	x	mm	495
	1.9	Wheelbase	y	mm	1740
	Weights	2.1.1	Service weight (incl. battery)		kg
2.2		Axle load laden front/rear		kg	5795 / 682
2.3		Axle load unladen front/rear		kg	1865 / 2112
Wheels/suspension system	3.1	Tyres			Super-elastic (SE)
	3.2	Tyre size, front			7.00-12
	3.3	Tyre size, rear			18x7-8
	3.5	Wheels, number front/back (x=driven)			2x / 2
	3.6	Tread width, front	b10	mm	975
	3.7	Tread width, rear	b11	mm	955
	Basic dimensions	4.1	Forward/backward tilt of mast	a/β	°
4.2		Retracted mast height (h1)	h1	mm	2090
4.3		Free lift (h2)	h2	mm	120
4.4		Lift (h3)	h3	mm	3000
4.5		Extended mast height (h4)	h4	mm	4025
4.7		Height of overhead guard (cab)	h6	mm	2165
4.8		Seat height/stand height	h7	mm	1095
4.12		Coupling height	h10	mm	311
4.19		total length	l1	mm	3695
4.20		Length including fork shank	l2	mm	2545
4.21.1		total width	b1	mm	1154
4.22		Fork dimensions	s/e/l	mm	40 x 122 x 1150
4.23		Fork carriage connection class			2A
4.24		Fork carriage width	b3	mm	1040
4.31		Ground clearance laden under mast	m1	mm	125
4.32		Ground clearance centre of wheelbase	m2	mm	170
4.34.1		Aisle width (pallet 1000x1200 sideways)	Ast	mm	3995
4.34.2		Aisle width (pallet 800x1200 length)	Ast	mm	4195
4.35		Turning radius	Wa	mm	2300
4.36		Smallest pivot point distance	b13	mm	838
Performance data	5.1	Travel speed laden/unladen		km/h	16 / 17
	5.2	Lift speed laden/unladen		m/s	0.5 / 0.56
	5.3	Lowering speed laden/unladen		m/s	0.54 / 0.56
	5.5	Drawbar pull laden/unladen		N	2270 / 2270
	5.6	Max. drawbar pull laden/unladen		N	13760 / 13760
	5.7	Gradeability laden/unladen		%	14 / 25
	5.8	Max. gradeability laden/unladen		%	20 / 25
	5.9	Acceleration time laden/unladen		s	6.6 / 6.4
	5.10	Service brake			hydraulic

E-motor/Electronics	6.1	Drive motor, performance S2 60 min	kW	17
	6.2	Lift motor, performance with S3	kW	26
	6.4	Battery voltage/nominal capacity	V / Ah	80 / 230
	6.6.1	Energy consumption according to EN cycle	kWh/h	7.1
	6.6.2	CO2 equivalent according to EN ISO 23308	kg/h0	3.84
	6.7	Throughput	t/h	150
	6.8.1	Energy consumption with max. throughput	kWh/h	6.21
Other	8.1	Type of drive control		AC
	10.1	Operating pressure for attachment	bar	180
	10.2	Oil flow for attachments	l/min	35
	10.7	Sound pressure level according to EN12053	dB (A)	74

- This data sheet according to VDI guideline 2198 only states the technical values of the standard truck. Different tyres, other masts, additional equipment etc. may result in different values.

VDI table (CBH 3.0)

Characteristic	1.1	Manufacturer (abbreviated description)			Jungheinrich
	1.2	Manufacturer's type designation			CBH 2.0-3.5
	1.3	Drive			Electric
	1.4	Operation			Seat
	1.5	Load capacity/load	Q	kg	3000
	1.6	Load centre distance	c	mm	500
	1.8	Load distance, centre of drive axle to fork	x	mm	481
	1.9	Wheelbase	y	mm	1740
	Weights	2.1.1	Service weight (incl. battery)		kg
2.2		Axle load laden front/rear		kg	6575 / 760
2.3		Axle load unladen front/rear		kg	1880 / 2455
Wheels/suspension system	3.1	Tyres			Super-elastic (SE)
	3.2	Tyre size, front			28x9-15
	3.3	Tyre size, rear			200/50-10
	3.5	Wheels, number front/back (x=driven)			2x / 2
	3.6	Tread width, front	b10	mm	1010
	3.7	Tread width, rear	b11	mm	955
	Basic dimensions	4.1	Forward/backward tilt of mast	a/β	°
4.2		Retracted mast height (h1)	h1	mm	2070
4.3		Free lift (h2)	h2	mm	135
4.4		Lift (h3)	h3	mm	3000
4.5		Extended mast height (h4)	h4	mm	4095
4.7		Height of overhead guard (cab)	h6	mm	2180
4.8		Seat height/stand height	h7	mm	1110
4.12		Coupling height	h10	mm	307
4.19		total length	l1	mm	3712
4.20		Length including fork shank	l2	mm	2562
4.21.1		total width	b1	mm	1210
4.22		Fork dimensions	s/e/l	mm	45 x 122 x 1150
4.23		Fork carriage connection class			3A
4.24		Fork carriage width	b3	mm	1100
4.31		Ground clearance laden under mast	m1	mm	130
4.32		Ground clearance centre of wheelbase	m2	mm	185
4.34.1		Aisle width (pallet 1000x1200 sideways)	Ast	mm	4060
4.34.2		Aisle width (pallet 800x1200 length)	Ast	mm	4260
4.35		Turning radius	Wa	mm	2379
4.36		Smallest pivot point distance	b13	mm	838
Performance data	5.1	Travel speed laden/unladen		km/h	16 / 17
	5.2	Lift speed laden/unladen		m/s	0.42 / 0.5
	5.3	Lowering speed laden/unladen		m/s	0.43 / 0.44
	5.5	Drawbar pull laden/unladen		N	2770 / 2770
	5.6	Max. drawbar pull laden/unladen		N	16280 / 16280
	5.7	Gradeability laden/unladen		%	12 / 23
	5.8	Max. gradeability laden/unladen		%	20 / 25
	5.9	Acceleration time laden/unladen		s	6.7 / 6.3
	5.10	Service brake			hydraulic

E-motor/Electronics	6.1	Drive motor, performance S2 60 min	kW	17
	6.2	Lift motor, performance with S3	kW	26
	6.4	Battery voltage/nominal capacity	V / Ah	80 / 230
	6.6.1	Energy consumption according to EN cycle	kWh/h	10.73
	6.6.2	CO2 equivalent according to EN ISO 23308	kg/h0	5.8
	6.7	Throughput	t/h	180
	6.8.1	Energy consumption with max. throughput	kWh/h	10.01
Other	8.1	Type of drive control		AC
	10.1	Operating pressure for attachment	bar	180
	10.2	Oil flow for attachments	l/min	35
	10.7	Sound pressure level according to EN12053	dB (A)	74

- This data sheet according to VDI guideline 2198 only states the technical values of the standard truck. Different tyres, other masts, additional equipment etc. may result in different values.

VDI table (CBH 3.5)

Characteristic	1.1	Manufacturer (abbreviated description)			Jungheinrich	
	1.2	Manufacturer's type designation			CBH 2.0-3.5	
	1.3	Drive			Electric	
	1.4	Operation			Seat	
	1.5	Load capacity/load	Q	kg	3500	-
	1.6	Load centre distance	c	mm	500	-
	1.8	Load distance, centre of drive axle to fork	x	mm	486	-
	1.9	Wheelbase	y	mm	1740	-
	Weights	2.1	tare weight		kg	4644
2.2		Axle load laden front/rear		kg	7355 / 789	- / -
2.3		Axle load unladen front/rear		kg	1870 / 2774	- / -
Wheels/suspension system	3.1	Tyres			Super-elastic (SE)	
	3.2	Tyre size, front			28x9-15	-
	3.3	Tyre size, rear			200/50-10	-
	3.5	Wheels, number front/back (x=driven)			2x / 2	-
	3.6	Tread width, front	b10	mm	1010	-
	3.7	Tread width, rear	b11	mm	955	-
	Basic dimensions	4.1	Forward/backward tilt of mast	a/B	°	6 / 10
4.2		Retracted mast height (h1)	h1	mm	2070	-
4.3		Free lift (h2)	h2	mm	135	-
4.4		Lift (h3)	h3	mm	3000	-
4.5		Extended mast height (h4)	h4	mm	4095	-
4.7		Height of overhead guard (cab)	h6	mm	2180	-
4.8		Seat height/stand height	h7	mm	1110	-
4.12		Coupling height	h10	mm	307	-
4.19		total length	l1	mm	3773	-
4.20		Length including fork shank	l2	mm	2623	-
4.21.1		total width	b1	mm	1210	-
4.22		Fork dimensions	s/e/l	mm	50 x 122 x 1150	
4.23		Fork carriage connection class			3A	
4.24		Fork carriage width	b3	mm	1100	-
4.31		Ground clearance laden under mast	m1	mm	130	-
4.32		Ground clearance centre of wheelbase	m2	mm	185	-
4.34.1		Aisle width (pallet 1000x1200 sideways)	Ast	mm	4114	-
4.34.2		Aisle width (pallet 800x1200 length)	Ast	mm	4314	-
4.35		Turning radius	Wa	mm	2428	-
4.36		Smallest pivot point distance	b13	mm	838	-
Performance data	5.1	Travel speed laden/unladen		km/h	16 / 17	- / -
	5.2	Lift speed laden/unladen		m/s	0.42 / 0.5	- / -
	5.3	Lowering speed laden/unladen		m/s	0.43 / 0.44	- / -
	5.5	Drawbar pull laden/unladen		N	3030 / 3030	- / -
	5.6	Max. drawbar pull laden/unladen		N	18100 / 18100	- / -
	5.7	Gradeability laden/unladen		%	10 / 19	-
	5.8	Max. gradeability laden/unladen		%	18 / 25	- / -
	5.9	Acceleration time laden/unladen		s	6.5 / 6	- / -
	5.10	Service brake			hydraulic	-

E-motor/Electronics	6.1	Drive motor, performance S2 60 min	kW	17	-
	6.2	Lift motor, performance with S3	kW	26	-
	6.4	Battery voltage/nominal capacity	V / Ah	80 / 280	-
	6.6.1	Energy consumption according to EN cycle	kWh/h	11.43	-
	6.6.2	CO2 equivalent according to EN ISO 23308	kg/h0	6.18	-
	6.7	Throughput	t/h	217	-
	6.8.1	Energy consumption with max. throughput	kWh/h	9.86	-
Other	8.1	Type of drive control		AC	-
	10.1	Operating pressure for attachment	bar	180	-
	10.2	Oil flow for attachments	l/min	35	-
	10.7	Sound pressure level according to EN12053	dB (A)	74	-

- This data sheet according to VDI guideline 2198 only states the technical values of the standard truck. Different tyres, other masts, additional equipment etc. may result in different values.

Appendix

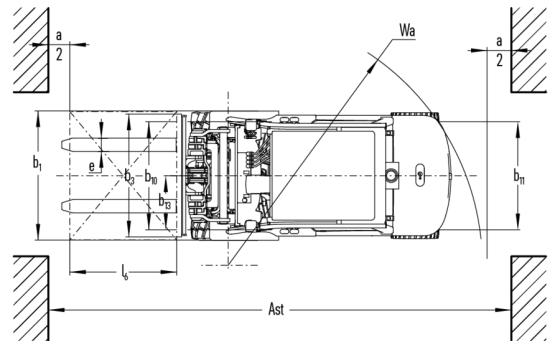
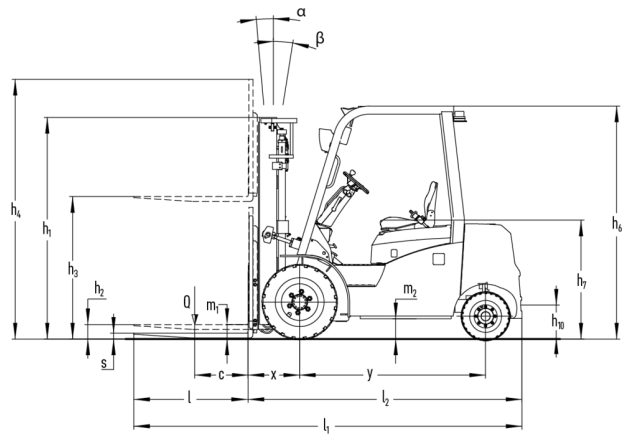
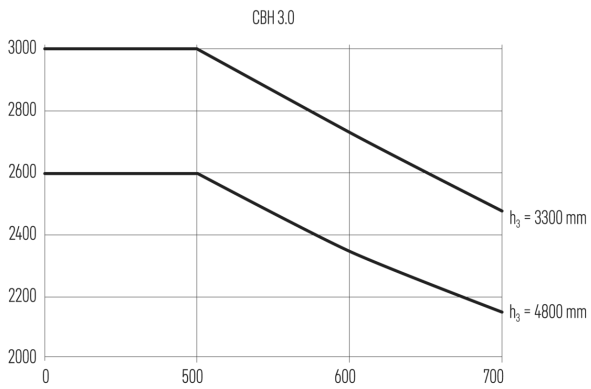
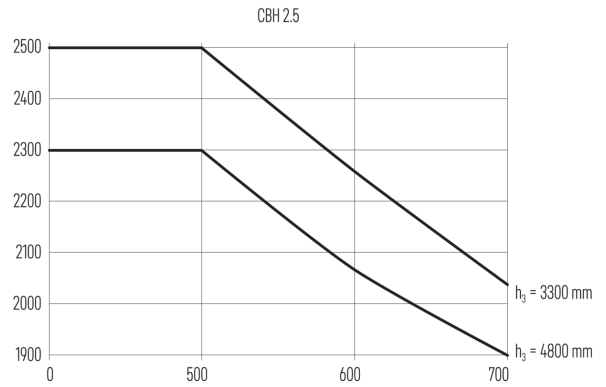
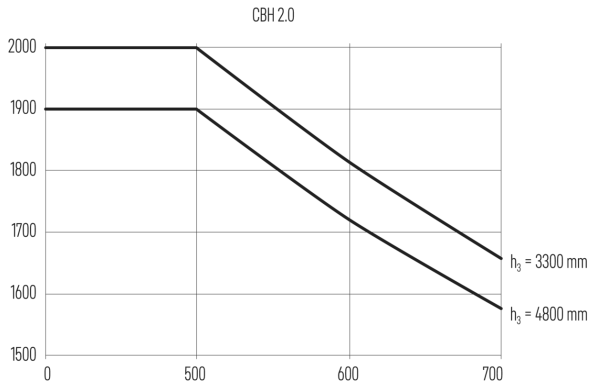

The German production facilities in
Norderstedt, Moosburg and Landsberg are
certified as well as our Genuine Parts
Center in Kaltenkirchen.

ISO 9001
ISO 14001

Jungheinrich fork lift trucks meet European
safety requirements.



anton
BY JUNGHEINRICH