



Electric pedestrian stacker with support arm lift

ERC 110zi/112zi

Lift height: 2300-4700 mm / Load capacity: 1000-1200 kg



ERC 110zi/112zi

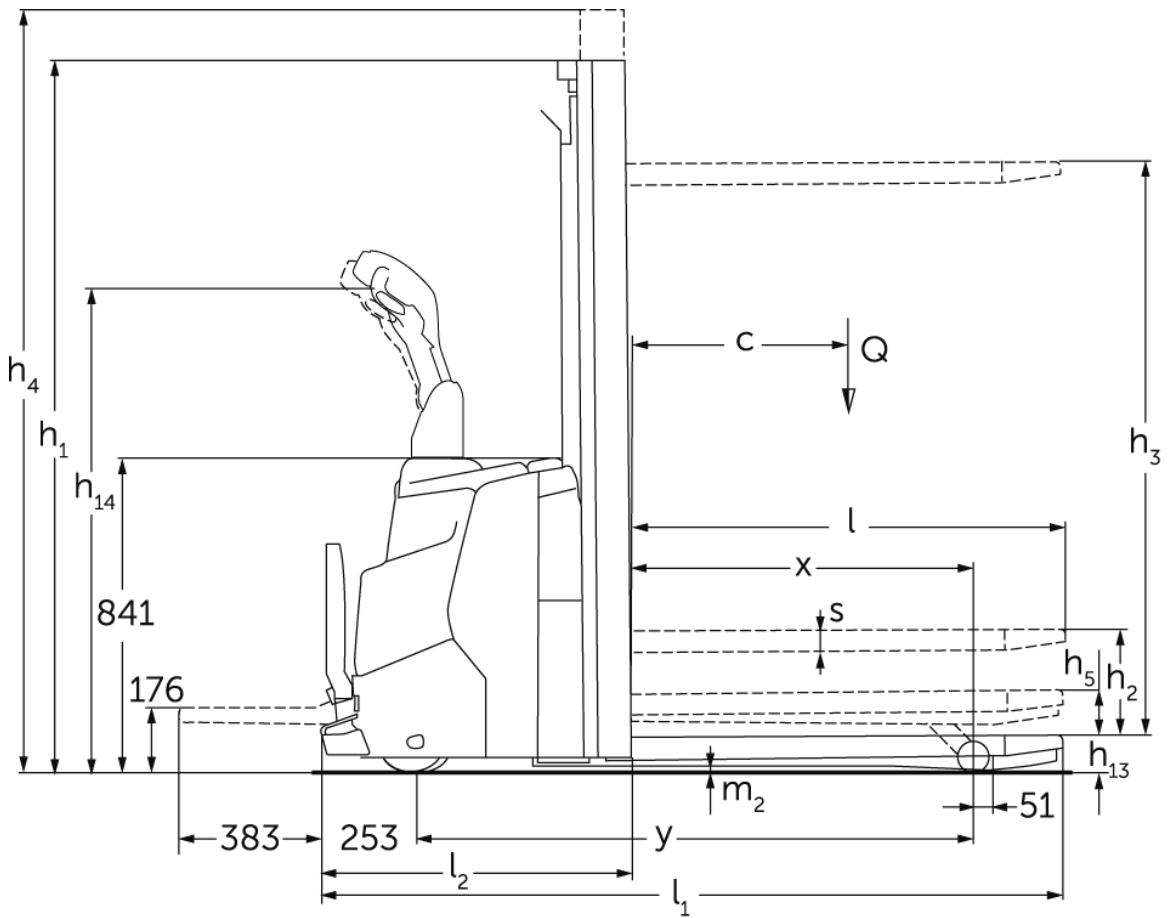

ERC 110zi/112zi

ERC 112zi	Lift (h3)	Retracted mast height (h1)	Free lift (h2)	Extended mast height (h4)
Duplex mast ZT	2300 mm	1650 mm	100 mm	2775 mm
	2500 mm	1750 mm	100 mm	2975 mm
	2700 mm	1850 mm	100 mm	3175 mm
	2900 mm	1950 mm	100 mm	3375 mm
	3200 mm	2100 mm	100 mm	3675 mm
	3600 mm	2300 mm	100 mm	4075 mm
	3900 mm	2450 mm	100 mm	4375 mm
	4100 mm	2550 mm	100 mm	4575 mm
	4300 mm	2650 mm	100 mm	4775 mm
Triplex mast DZ	4700 mm	2050 mm	1564 mm	5213 mm

VDI table

Characteristic	1.1	Manufacturer (abbreviated description)			Jungheinrich
	1.3	Drive			Electric
	1.4	Operation			Pedestrian
	1.5	Load capacity/load	Q	kg	1200
	1.5.1	Rated capacity/load with mast lift	Q	kg	1200
	1.5.2	Rated capacity/load with support arm lift	Q	kg	1600
	1.6	Load centre distance	c	mm	600
	1.8	Load distance, centre of drive axle to fork	x	mm	965
	1.9	Wheelbase	y	mm	1544
Weights	2.1.1	Service weight (incl. battery)		kg	925
	2.2	Axle load laden front/rear		kg	945 / 1180
	2.3	Axle load unladen front/rear		kg	675 / 250
Wheels/suspension system	3.1	Tyres			Polyurethane (PU)
	3.2	Tyre size, front			Ø 230 x 70
	3.3	Tyre size, rear			Ø 85 x 95 / Ø 85 x 75
	3.4	Additional wheels			Ø 140 x 54
	3.5	Wheels, number front/back (x=driven)			1x + 1/2
	3.6	Tread width, front	b10	mm	507
	3.7	Tread width, rear	b11	mm	385
Basic dimensions	4.2	Retracted mast height (h1)	h1	mm	1950
	4.3	Free lift (h2)	h2	mm	100
	4.4	Lift (h3)	h3	mm	2900
	4.5	Extended mast height (h4)	h4	mm	3375
	4.6	Initial lift	h5	mm	122
	4.8	Seat height/stand height	h7	mm	176
	4.9	Height of tiller handle in drive position min./max.	h14	mm	1037 / 1293
	4.15	Height, lowered	h13	mm	90
	4.19	total length	l1	mm	1982
	4.20	Length including fork shank	l2	mm	832
	4.21.1	total width	b1	mm	800
	4.22	Fork dimensions	s/e/l	mm	56 x 185 x 1150
	4.25	Width across forks	b5	mm	570
	4.32	Ground clearance centre of wheelbase	m2	mm	18
Performance data	5.1	Travel speed laden/unladen		km/h	6 / 6
	5.2	Lift speed laden/unladen		m/s	0.16 / 0.29
	5.3	Lowering speed laden/unladen		m/s	0.41 / 0.37
	5.8	Max. gradeability laden/unladen		%	5 / 10
	5.10	Service brake			generative

E-motor/Electronics	6.1	Drive motor, performance S2 60 min	kW	0.9
	6.2	Lift motor, performance with S3	kW	2.2
	6.3	Battery according to DIN 43531/35/36		no
	6.4	Battery voltage/nominal capacity	V / Ah	24 / 105
	6.5	Battery weight	kg	45
	6.6.1	Energy consumption according to EN cycle	kWh/h	0.83
	6.6.2	CO2 equivalent according to EN ISO 23308	kg/h0	0.45
	6.7	Throughput	t/h	45
	6.8.1	Energy consumption with max. throughput	kWh/h	1.18
Other	8.1	Type of drive control		AC
	10.7	Sound pressure level according to EN12053	dB (A)	64.6

- This data sheet according to VDI guideline 2198 only states the technical values of the standard truck. Different tyres, other masts, additional equipment etc. may result in different values.

The values in the table apply for the S battery compartment, ZT2900 mast, battery 105 Ah.

- VDI no. 1.8: with DZ mast: x - 40 mm. Raised support arms: - 51 mm.
- VDI no. 4.19: with DZ mast: l1 + 40 mm. Bottom platform: + 383 mm.
- VDI no. 4.20: with DZ mast: l2 + 40 mm. Bottom platform: + 383 mm.
- VDI no. 4.34.1: diagonal as per VDI: aisle width + 370 mm; with DZ mast: aisle width +40 mm; bottom platform: + 383 mm.
- VDI no. 4.34.2: diagonal as per VDI: aisle width + 206 mm; with DZ mast: aisle width +40 mm; bottom platform: + 383 mm.
- VDI no. 4.35: Bottom platform: + 367 mm; raised support arms: - 51 mm.
- VDI no. 5.8: the values in the table relate to the rated load (1.5). With maximum load in the support arm lift (1.5.2): max. gradeability laden = 3.5%.
- VDI no. 6.2: ERC 110zi: S3 5%; ERC 112zi: S3 10%.

The German production facilities in
Norderstedt, Moosburg and Landsberg are
certified as well as our Genuine Parts
Center in Kaltenkirchen.

ISO 9001
ISO 14001

Jungheinrich fork lift trucks meet European
safety requirements.



 **JUNGHEINRICH**

The Jungheinrich logo, featuring a red upward-pointing arrow above the word 'JUNGHEINRICH' in a bold, black, sans-serif font.