



Electric pedestrian pallet truck with ergonomic lift

EJE C20i

Lift height: 662 mm / Load capacity: 2000 kg

LION
technology

JUNGHEINRICH

EJE C20i

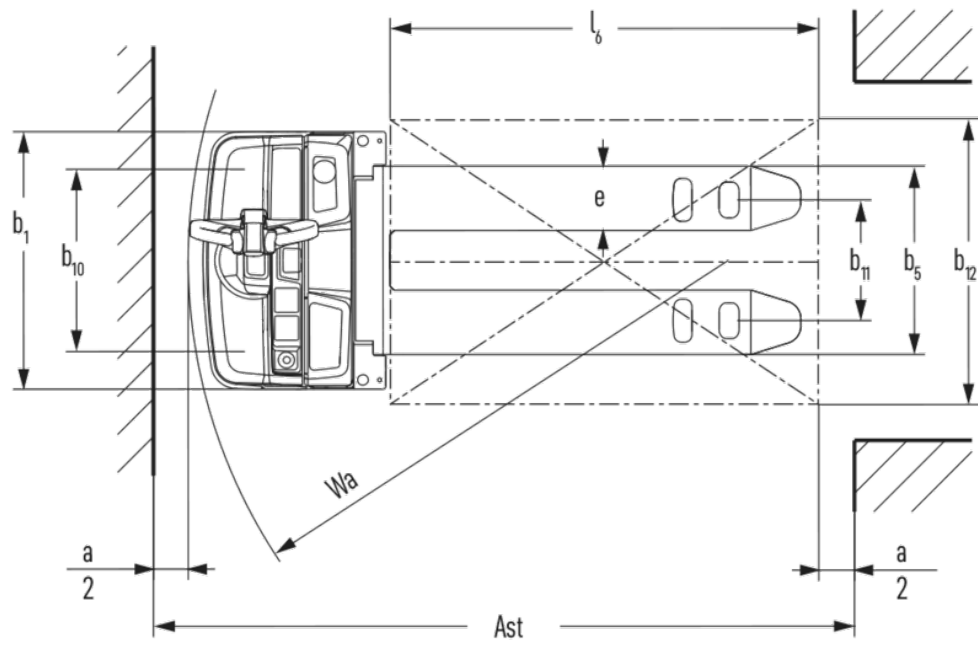
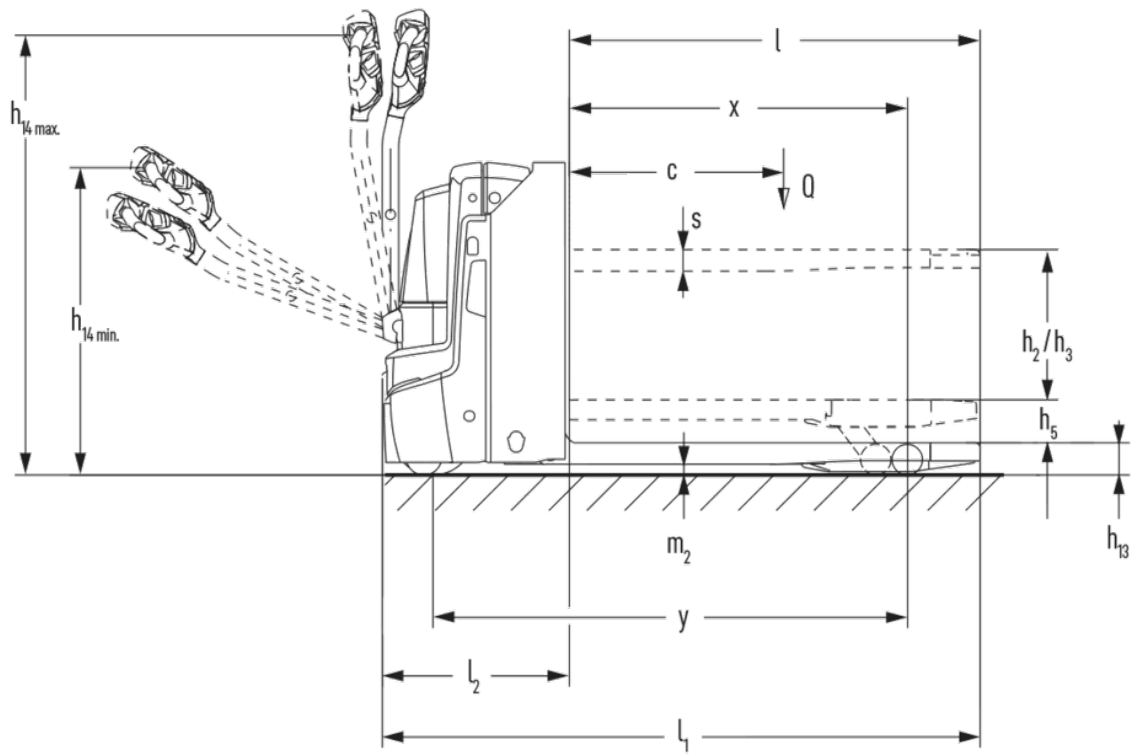

VDI table

Characteristic	1.1	Manufacturer (abbreviated description)			Jungheinrich
	1.2	Manufacturer's type designation			EJE C20i
	1.3	Drive type			electric
	1.4	Operation			Pedestrian
	1.5	Load capacity/load	Q	kg	2000
	1.5.1	Rated capacity/load with mast lift	Q	kg	700
	1.5.2	Rated capacity/load with support arm lift	Q	kg	2000
	1.6	Load centre distance	c	mm	600
	1.8	Load distance, centre of drive axle to fork	x	mm	880
	1.9	Wheelbase	y	mm	1262
Weights	2.1.1	Service weight (incl. battery)		kg	426
	2.2	Axle load laden front/rear		kg	810 / 1610
	2.3	Axle load unladen front/rear		kg	322 / 104
Wheels/chassis	3.1	Tyres			Polyurethane (PU)
	3.2	Tyre size, front			Ø 230 x 70
	3.3	Tyre size, rear			Ø 85 x 95 / Ø 85 x 70
	3.4	Additional wheels			Ø 100 x 40
	3.5	Wheels, number front/back (x=driven)			1x +2/2 oder 4
	3.6	Tread width, front	b10	mm	510
	3.7	Tread width, rear	b11	mm	338
Basic dimensions	4.3	Free lift (h2)	h2	mm	540
	4.4	Lift (h3)	h3	mm	540
	4.6	Initial lift	h5	mm	122
	4.9	Height of tiller handle in drive position min./max.	h14	mm	690 / 1235
	4.15	Height, lowered	h13	mm	90
	4.19	Total length	l1	mm	1674
	4.20	Length including fork shank	l2	mm	524
	4.21.1	total width	b1	mm	720
	4.22	Fork dimensions	s/e/l	mm	60 x 180 x 1150
	4.25	Width across forks	b5	mm	527
	4.32	Ground clearance centre of wheelbase	m2	mm	30
	4.34.1	Aisle width (pallet 1000x1200 sideways)	Ast	mm	2257
	4.34.2	Aisle width (pallet 800x1200 length)	Ast	mm	2157
4.35	Turning radius	Wa	mm	1445	
Performance data	5.1	Travel speed laden/unladen		km/h	6 / 6
	5.2	Lift speed laden/unladen		m/s	0.19 / 0.3
	5.3	Lowering speed laden/unladen		m/s	0.2 / 0.2
	5.8	Max. gradeability laden/unladen		%	10 / 20
	5.10	Service brake			generative

Electric motor/electronics	6.1	Drive motor, performance S2 60 min	kW	1.1
	6.2	Lift motor, performance with S3	kW	1.2
	6.3	Battery according to DIN 43531/35/36		no
	6.4	Battery voltage/nominal capacity	V / Ah	25.6 / 50
	6.5	Battery weight	kg	23.8
	6.6.1	Energy consumption according to EN cycle	kWh/h	0.32
	6.6.2	CO2 equivalent according to EN ISO 23308	kg/h0	0.2
	6.7	Throughput	t/h	108
Other	8.1	Type of drive control		AC
	10.7	Sound pressure level according to EN12053	dB (A)	59
<p>- This data sheet according to VDI guideline 2198 only states the technical values of the standard truck. Different tyres, other masts, additional equipment etc. may result in different values.</p>				

The values in the table apply to a truck with an XS battery compartment.

- VDI no. 1.8: lowered load section: $x + 67$ mm.
- VDI no. 1.9: lowered load section: $y + 67$ mm; with S battery compartment: $y + 50$ mm.
- VDI no. 4.19: with S battery compartment: $l1 + 50$ mm.
- VDI no. 4.20: with S battery compartment: $l2 + 50$ mm.
- VDI no. 4.34.1: with S battery compartment: aisle width $+ 50$ mm.
- VDI no. 4.34.2: with S battery compartment: aisle width $+ 50$ mm.
- VDI no. 4.35: lowered load section: $Wa + 67$ mm; with S battery compartment: $Wa + 50$ mm.

The German production facilities in
Norderstedt, Moosburg and Landsberg are
certified as well as our Genuine Parts
Center in Kaltenkirchen.

ISO 9001
ISO 14001

Jungheinrich fork lift trucks meet European
safety requirements.



 **JUNGHEINRICH**

The Jungheinrich logo, featuring a red upward-pointing arrow above the word 'JUNGHEINRICH' in a bold, black, sans-serif font.