



Electric pedestrian stacker

ERC 212–220

Lift height: 2400-6000 mm / Load capacity: 1200-2000 kg



ERC 212-220

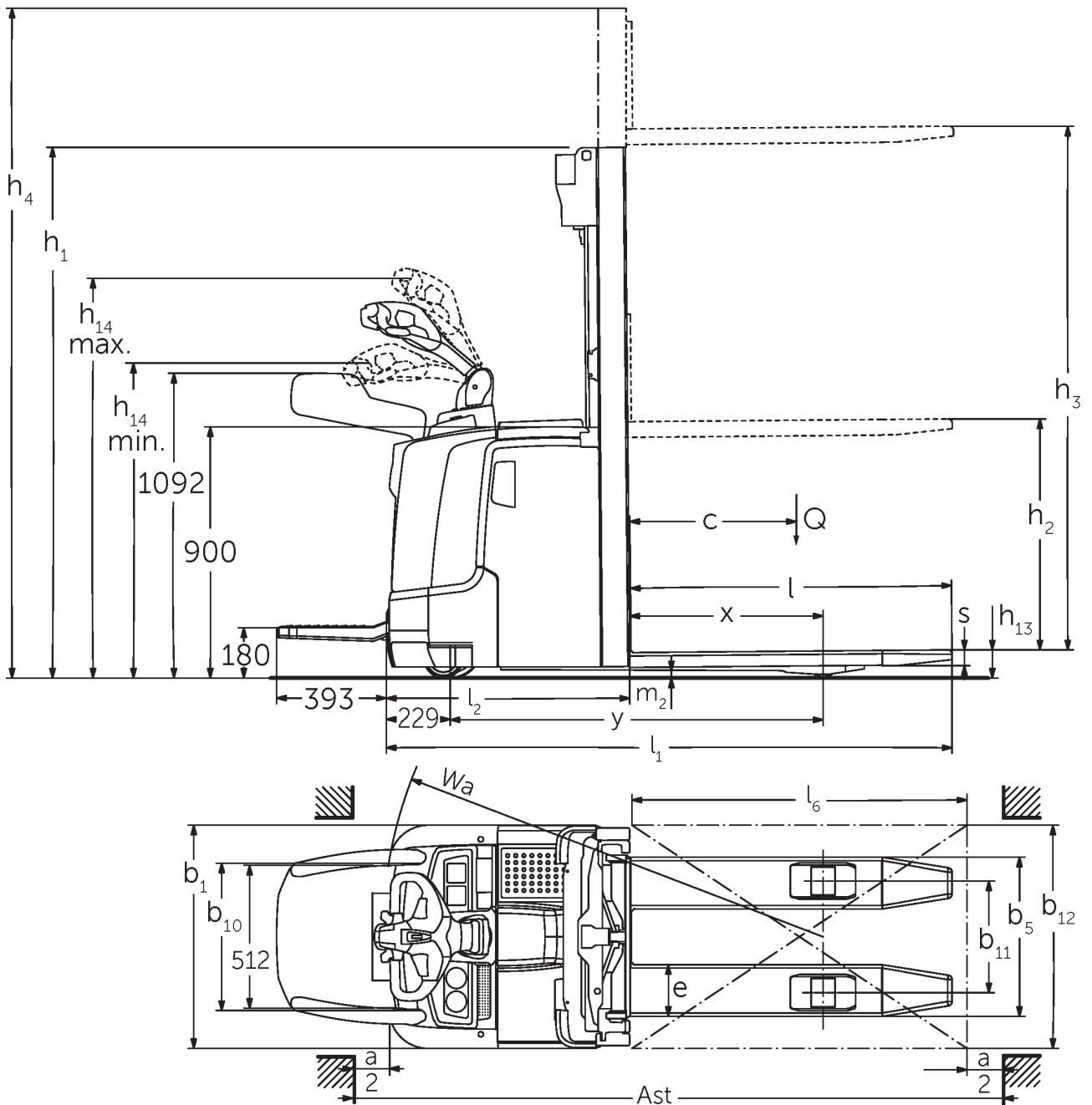

Dimensional drawing ERC 2

ERC 212–220

ERC 212	Lift (h3)	Retracted mast height (h1)	Free lift (h2)	Extended mast height (h4)
Duplex mast ZT	2500 mm	1750 mm	100 mm	2975 mm
	2700 mm	1850 mm	100 mm	3175 mm
	2900 mm	1950 mm	100 mm	3375 mm
	3200 mm	2100 mm	100 mm	3675 mm
	3600 mm	2300 mm	100 mm	4075 mm
	4100 mm	2550 mm	100 mm	4575 mm
	4300 mm	2650 mm	100 mm	4775 mm
Duplex mast ZZ	2500 mm	1700 mm	1225 mm	2975 mm
	2900 mm	1900 mm	1425 mm	3375 mm
	3200 mm	2050 mm	1575 mm	3675 mm
	3600 mm	2250 mm	1775 mm	4075 mm
	4100 mm	2500 mm	2025 mm	4575 mm
	4300 mm	2600 mm	2125 mm	4775 mm
Triplex mast DZ	4090 mm	1845 mm	1338 mm	4597 mm
	4300 mm	1915 mm	1408 mm	4807 mm
	4700 mm	2050 mm	1543 mm	5207 mm
ERC 214	Lift (h3)	Retracted mast height (h1)	Free lift (h2)	Extended mast height (h4)
Duplex mast ZT	2500 mm	1750 mm	100 mm	2975 mm
	2700 mm	1850 mm	100 mm	3175 mm
	2900 mm	1950 mm	100 mm	3375 mm
	3200 mm	2100 mm	100 mm	3675 mm
	3600 mm	2300 mm	100 mm	4075 mm
	4100 mm	2550 mm	100 mm	4575 mm
	4300 mm	2650 mm	100 mm	4775 mm
	4500 mm	2750 mm	100 mm	4975 mm
Duplex mast ZZ	2500 mm	1700 mm	1225 mm	2975 mm
	2900 mm	1900 mm	1425 mm	3375 mm
	3200 mm	2050 mm	1575 mm	3675 mm

	3600 mm	2250 mm	1775 mm	4075 mm
	4100 mm	2500 mm	2025 mm	4575 mm
	4300 mm	2600 mm	2125 mm	4775 mm
Triplex mast DZ	4090 mm	1830 mm	1341 mm	4579 mm
	4300 mm	1900 mm	1411 mm	4789 mm
	4690 mm	2030 mm	1541 mm	5179 mm
	5350 mm	2250 mm	1761 mm	5839 mm
ERC 214, ERC 216	Lift (h3)	Retracted mast height (h1)	Free lift (h2)	Extended mast height (h4)
Triplex mast DZ	6000 mm	2500 mm	1968 mm	6532 mm
ERC 216	Lift (h3)	Retracted mast height (h1)	Free lift (h2)	Extended mast height (h4)
Duplex mast ZT	2400 mm	1750 mm	100 mm	2925 mm
	2600 mm	1850 mm	100 mm	3125 mm
	2800 mm	1950 mm	100 mm	3325 mm
	3100 mm	2100 mm	100 mm	3625 mm
	3500 mm	2300 mm	100 mm	4025 mm
	3800 mm	2450 mm	100 mm	4325 mm
	4000 mm	2550 mm	100 mm	4525 mm
	4200 mm	2650 mm	100 mm	4725 mm
	4400 mm	2750 mm	100 mm	4925 mm
Duplex mast ZZ	2400 mm	1700 mm	1175 mm	2925 mm
	2800 mm	1900 mm	1375 mm	3325 mm
	3100 mm	2050 mm	1525 mm	3625 mm
	3500 mm	2250 mm	1725 mm	4025 mm
	4000 mm	2500 mm	1975 mm	4525 mm
	4200 mm	2600 mm	2075 mm	4725 mm
Triplex mast DZ	3990 mm	1830 mm	1298 mm	4522 mm
	4200 mm	1900 mm	1368 mm	4732 mm
	4590 mm	2030 mm	1498 mm	5122 mm
	5250 mm	2250 mm	1718 mm	5782 mm

ERC 220	Lift (h3)	Retracted mast height (h1)	Free lift (h2)	Extended mast height (h4)
Duplex mast ZT	2540 mm	1950 mm	100 mm	3195 mm
	2840 mm	2100 mm	100 mm	3495 mm
	3540 mm	2450 mm	100 mm	4195 mm
Duplex mast ZZ	2540 mm	1900 mm	1245 mm	3195 mm
	2840 mm	2050 mm	1395 mm	3495 mm
	3540 mm	2400 mm	1745 mm	4195 mm
Triplex mast DZ	3750 mm	1900 mm	1218 mm	4432 mm
	4200 mm	2050 mm	1368 mm	4882 mm
	4800 mm	2250 mm	1568 mm	5482 mm

VDI table

		Jungheinrich					
		ERC 212	ERC 214	ERC 216	ERC 220		
Characteristic	1.1	Manufacturer (abbreviated description)					
	1.2	Manufacturer's type designation					
	1.3	Drive type	electric				
	1.4	Operation	Pedestrian				
	1.5	Load capacity/load	Q kg	1200	1400	1600	2000
	1.6	Load centre distance	c mm	600			
	1.8	Load distance, centre of drive axle to fork	x mm	688	667		
	1.9	Wheelbase	y mm	1264		1336	
	Weights	2.1.1	Service weight (incl. battery)	kg	1130	1200	1220
2.2		Axle load laden front/rear	kg	890 / 1440	960 / 1640	980 / 1840	983 / 2332
2.3		Axle load unladen front/rear	kg	830 / 300	880 / 320	890 / 330	924 / 392
Wheels/chassis	3.1	Tyres	Polyurethane (PU)				
	3.2	Tyre size, front	Ø 230 x 77				
	3.3	Tyre size, rear	Ø 85 x 110 / 85		Ø 85 x 85		
	3.4	Additional wheels	Ø 140 x 54				
	3.5	Wheels, number front/back (x=driven)	1x +1/2		1x +1/4		
	3.6	Tread width, front	b10 mm	515			
	3.7	Tread width, rear	b11 mm	400			
Basic dimensions	4.2	Retracted mast height (h1)	h1 mm	1950		2100	
	4.3	Free lift (h2)	h2 mm	100			
	4.4	Lift (h3)	h3 mm	2900	2800	2840	
	4.5	Extended mast height (h4)	h4 mm	3375	3325	3495	
	4.9	Height of tiller handle in drive position min./max.	h14 mm	1170 / 1390			
	4.15	Height, lowered	h13 mm	90			
	4.19	Total length	l1 mm	1955	1976	2048	
	4.20	Length including fork shank	l2 mm	805	826	898	
	4.21.1	total width	b1 mm	800			
	4.22	Fork dimensions	s/ e/l mm	56 x 185 x 1150			
	4.25	Width across forks	b5 mm	570			
	4.32	Ground clearance centre of wheelbase	m2 mm	28		18	
	4.34.1	Aisle width (pallet 1000x1200 sideways)	Ast mm	2170	2191	2263	
	4.34.2	Aisle width (pallet 800x1200 length)	Ast mm	2220	2241	2313	
4.35	Turning radius	Wa mm	1508		1580		
Performance data	5.1	Travel speed laden/unladen (Efficiency drivePLUS)	km/h	6 / 6 9 / 11		6 / 6 8 / 10	
	5.2	Lift speed laden/unladen	m/s	0.2 / 0.4	0.16 / 0.3	0.15 / 0.3	0.11 / 0.34
	5.3	Lowering speed laden/unladen	m/s	0.45 / 0.35		0.5 / 0.35	
	5.8	Max. gradeability laden/unladen (Efficiency drivePLUS)	%	10 / 16 10 / 20	9 / 16 10 / 20	8 / 16 10 / 20	5 / 16 6 / 16
	5.10	Service brake		generative			

Electric motor/electronics	6.1	Drive motor, performance S2 60 min (Efficiency drivePLUS)	kW	2.8 3.2			
	6.2	Lift motor, performance with S3	kW	3			
	6.3	Battery according to DIN 43531/35/36		DIN 43535 B			
	6.4	Battery voltage/nominal capacity	V / Ah	24 / 300		24 / 375	
	6.5	Battery weight	kg	238		273	
	6.6	Energy consumption according to VDI cycle	kWh/h	-			
	6.6.1	Energy consumption according to EN cycle (Efficiency PLUS)	kWh/h	0.63 0.64	0.81 0.76	0.86 0.83	1.07 -
	6.6.2	CO2 equivalent according to EN ISO 23308 (Efficiency PLUS)	kg/h0	0.34 0.3	0.44 0.4	0.46 0.4	0.58 -
	6.7	Throughput (Efficiency PLUS)	t/h	56 57	64 65	71 73	85 -
6.8.1	Energy consumption with max. throughput (Efficiency PLUS)	kWh/h	1.63 1.65	1.65 1.64	1.67 1.65	2.13 -	
Other	8.1	Type of drive control		AC			
	10.7	Sound pressure level according to EN12053	dB (A)	64			

- This data sheet according to VDI guideline 2198 only states the technical values of the standard truck. Different tyres, other masts, additional equipment etc. may result in different values.

The values in the table apply for the battery compartment M-VBE (ERC 212 / 214 / 216), L-VBE / LBE (ERC 220); mast ZT2800 / 2840 / 2900 mm.

- VDI no. 1.8 with ERC 212 / 214 / 216: with DZ mast: x - 42 mm.
- VDI no. 1.8 with ERC 220: with L-VBE or L-SBE battery compartment and DZ mast: x - 1 mm, M Li-ion and DZ mast: x - 71 mm.
- VDI no. 1.9 with ERC 212 / 214 / 216: with M Li-ion battery compartment: y + 0 mm, L-VBE or L-SBE: y + 72 mm.
- VDI no. 1.9 with ERC 220: with L-VBE or L-SBE battery compartment and DZ mast: y + 70 mm, M Li-ion: y - 72 mm.
- VDI no. 3.3: tandem: Ø 85 x 75 mm.
- VDI no. 4.19 with ERC 212 / 214 / 216: with DZ mast: l1 + 42 mm; with M Li-ion battery compartment: l1 + 0 mm, L-VBE or L-SBE: l1 + 72 mm.
- VDI no. 4.19 with ERC 220: with DZ mast: l1 + 71 mm. with M Li-ion battery compartment: l1 - 72 mm.
- VDI no. 4.20 with ERC 212 / 214 / 216: with DZ mast: l2 + 42 mm; with M Li-ion battery compartment: l2 + 0 mm, L-VBE or L-SBE: l2 + 72 mm.
- VDI no. 4.20 with ERC 220: with DZ mast: l2 + 71 mm. with M Li-ion battery compartment: l2 - 72 mm.
- VDI no. 4.34.1 with ERC 212 / 214 / 216: diagonal as per VDI: aisle width + 215 mm; with M Li-ion battery compartment: aisle width + 0 mm, L-VBE or L-SBE: aisle width + 72 mm; with DZ mast: aisle width + 42 mm.
- VDI no. 4.34.1 with ERC 220: diagonal as per VDI: aisle width + 215 mm; with DZ mast: aisle width + 71 mm. with M Li-ion battery compartment: aisle width - 72 mm.
- VDI no. 4.34.2 with ERC 212 / 214 / 216: diagonal as per VDI: aisle width + 138 mm; with M Li-ion battery compartment: aisle width + 0 mm, L-VBE or L-SBE: aisle width + 72 mm; with DZ mast: aisle width + 42 mm.
- VDI no. 4.34.2 with ERC 220: diagonal as per VDI: aisle width + 138 mm; with DZ mast: aisle width + 71 mm. with M Li-ion battery compartment: aisle width - 72 mm.
- VDI no. 4.35 with ERC 212 / 214 / 216: with M Li-ion battery compartment: Wa + 0 mm, L-VBE or L-SBE: Wa + 72 mm.
- VDI no. 4.35 with ERC 220: with DZ mast: Wa + 70 mm; with M Li-ion battery compartment: Wa - 72 mm.
- VDI no. 5.1: with Efficiency performance package without operator restraint system: 6.0 / 6.0 km/h; with operator restraint system: 7.0 / 7.0 km/h.
- VDI no. 5.3: with ZZ / DZ mast: the lowering speed in free lift is below the specified values.

The German production facilities in
Norderstedt, Moosburg and Landsberg are
certified as well as our Genuine Parts
Center in Kaltenkirchen.

ISO 9001
ISO 14001

Jungheinrich fork lift trucks meet European
safety requirements.



 **JUNGHEINRICH**

The logo features a red arrow pointing upwards, positioned to the left of the word 'JUNGHEINRICH' in a bold, black, sans-serif font.