



Medium/high level order picker

EKS 310/412

Lift height: 7000-9000 mm / Load capacity: 1200 kg



EKS 310/412

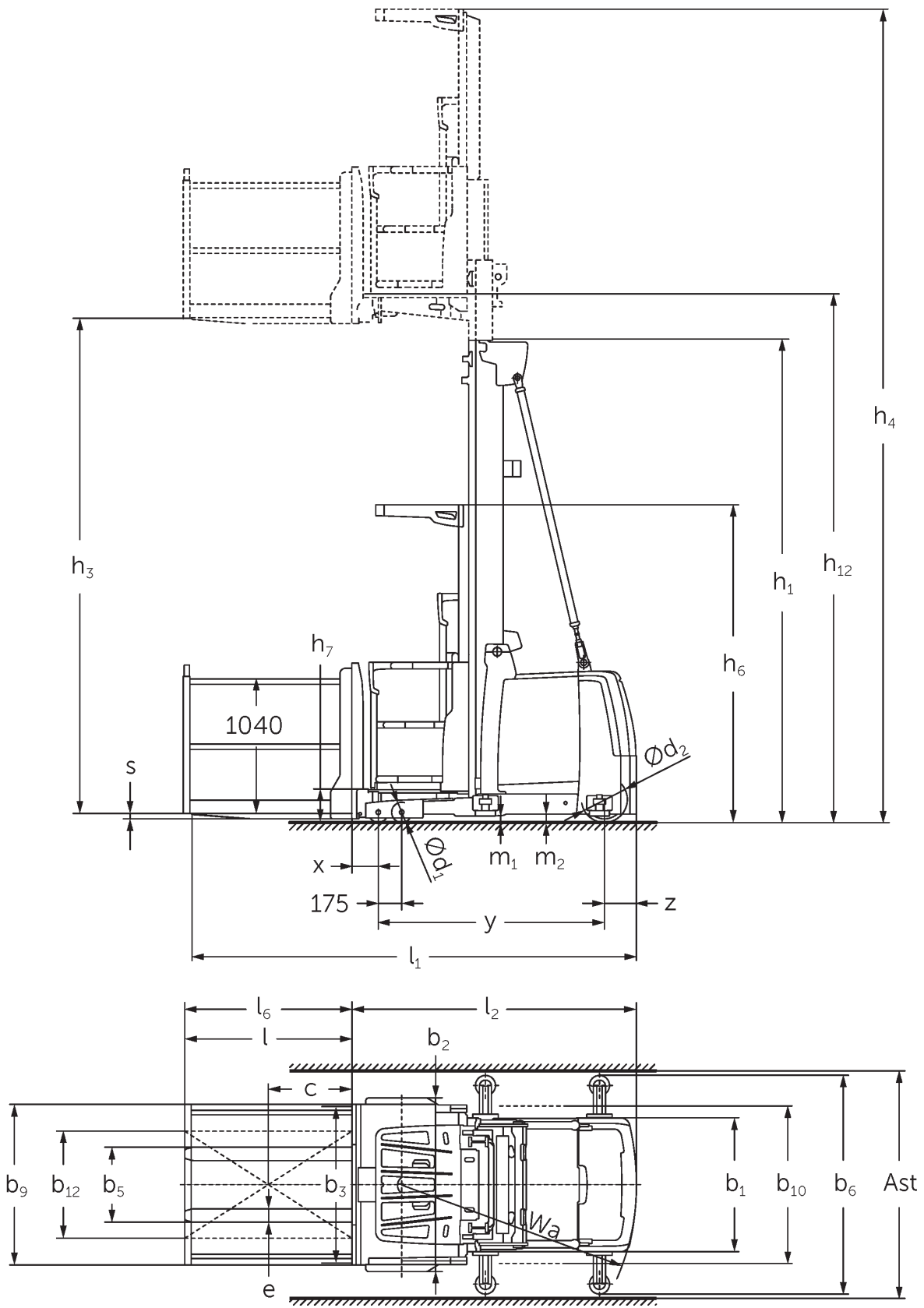

EKS 3/4 L version technical drawing



EKS 3/4 0 version technical drawing

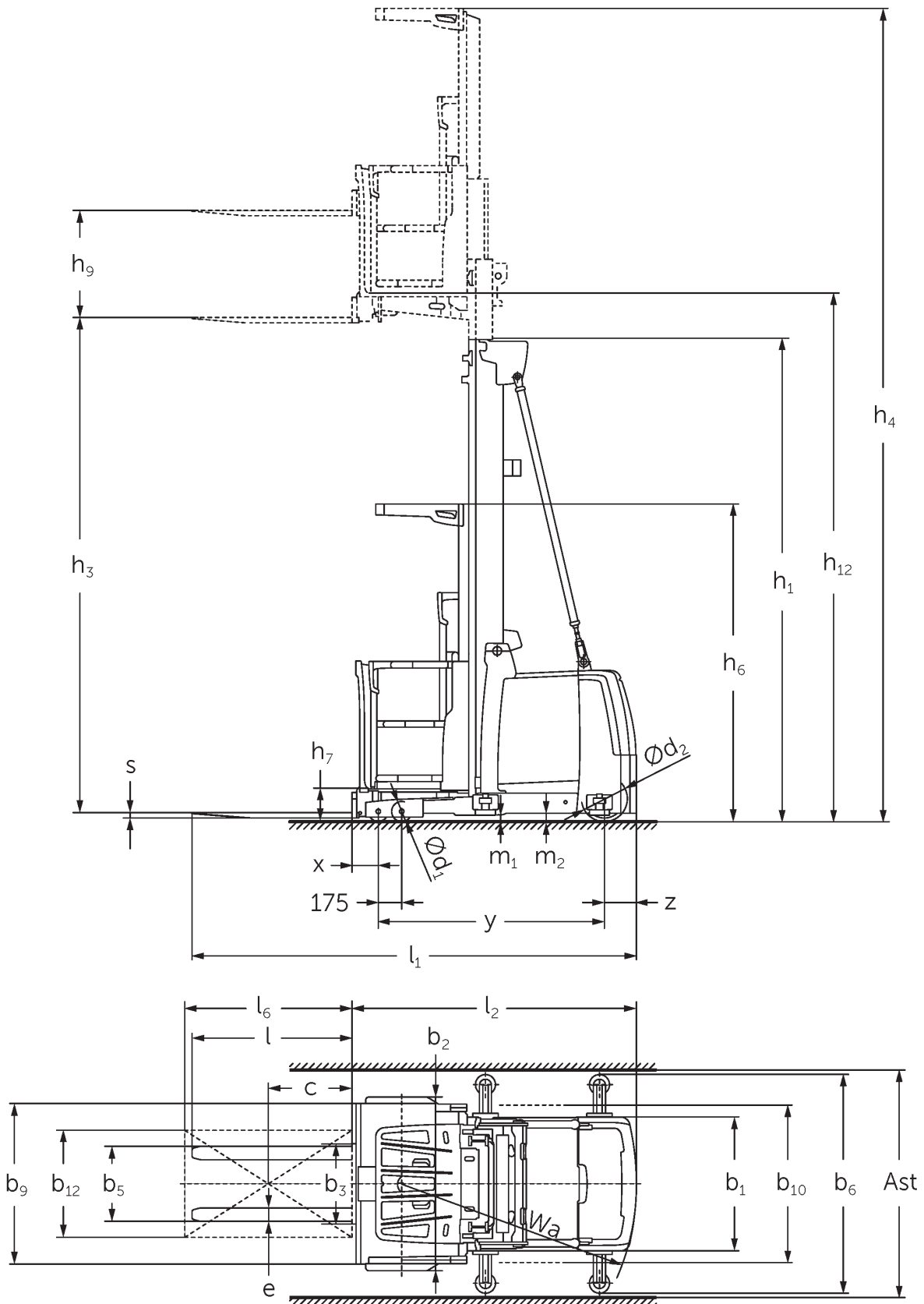

EKS 3/4 Z version technical drawing

EKS 310/412

EKS 310 Z, EKS 310 L, EKS 310 O	Lift (h3)	Retracted mast height (h1)	Free lift (h2)	Extended mast height (h4)
Duplex mast ZT	2800 mm	2325 mm		5170 mm
	3500 mm	2550 mm		5870 mm
Triplex mast DT	4750 mm	2370 mm		7120 mm
Triplex mast DZ	4750 mm	2370 mm		7120 mm
EKS 310 Z, EKS 310 L, EKS 310 O, EKS 412 Z, EKS 412 L, EKS 412 O	Lift (h3)	Retracted mast height (h1)	Free lift (h2)	Extended mast height (h4)
Duplex mast ZT	4250 mm	2950 mm		6620 mm
	5000 mm	3330 mm		7370 mm
	5500 mm	3600 mm		7870 mm
	6000 mm	3850 mm		8370 mm
Triplex mast DT	5500 mm	2610 mm		7870 mm
	6000 mm	2780 mm		8370 mm
	6500 mm	2940 mm		8870 mm
	7000 mm	3110 mm		9370 mm
Triplex mast DZ	5500 mm	2610 mm	240 mm	7870 mm
	6000 mm	2780 mm	410 mm	8370 mm
	6500 mm	2940 mm	570 mm	8870 mm
	7000 mm	3110 mm	740 mm	9370 mm
EKS 412 Z, EKS 412 L, EKS 412 O	Lift (h3)	Retracted mast height (h1)	Free lift (h2)	Extended mast height (h4)
Duplex mast ZT	6500 mm	4125 mm		8870 mm
	7500 mm	4650 mm		9870 mm
	8500 mm	5150 mm		10870 mm
Triplex mast DT	7500 mm	3275 mm		9870 mm
	8000 mm	3440 mm		10370 mm
	8500 mm	3610 mm		10870 mm
	9000 mm	3810 mm		11370 mm

Triplex mast DZ	7500 mm	3275 mm	905 mm	9870 mm
	8000 mm	3440 mm	1070 mm	10370 mm
	8500 mm	3610 mm	1240 mm	10870 mm
	9000 mm	3810 mm	1440 mm	11370 mm

VDI table

		Jungheinrich									
Characteristic	1.1	Manufacturer (abbreviated description)									
	1.2	Manufacturer's type designation	EKS 310 Z	EKS 310 L	EKS 310 O	EKS 412 Z	EKS 412 L	EKS 412 O			
	1.3	Drive type	electric								
	1.4	Operation	Order pickers								
	1.5	Load capacity/load	Q	kg	1000		1200				
	1.6	Load centre distance	c	mm	400						
	1.8	Load distance, centre of drive axle to fork	x	mm	155						
	1.9	Wheelbase	y	mm	1520		1690				
Weights	2.1.1	Service weight (incl. battery)		kg	2550		2500	3450		3400	
	2.2	Axle load laden front/rear		kg	2740 / 860	2770 / 830	2695 / 855	3425 / 1255	3455 / 1195	3380 / 1220	
	2.3	Axle load unladen front/rear		kg	1215 / 1335	1270 / 1330	1195 / 1355		1655 / 1795	1580 / 1820	
Wheels/chassis	3.1	Tyres	Polyurethane (PU)								
	3.2	Tyre size, front	Ø 150 x 100								
	3.3	Tyre size, rear	Ø 250 x 80				Ø 343 x 114				
	3.4										
	3.5	Wheels, number front/back (x=driven)	4 / 1 x								
Basic dimensions	4.2	Retracted mast height (h1)		h1	mm	2950		3330			
	4.4	Lift (h3)		h3	mm	4250		5000			
	4.5	Extended mast height (h4)		h4	mm	6620		7370			
	4.7	Height of overhead guard (cab)		h6	mm	2370					
	4.8.1	Stand height		h7	mm	245					
	4.14	Stand height, elevated		h12	mm	4495		5245			
	4.15	Height, lowered		h13	mm	60					
	4.19	Total length		l1	mm	3095	3140	3085	3285	3330	3275
	4.20	Length including fork shank		l2	mm	1895	1885		2085	2075	
	4.21.1	total width		b1	mm	900			1000		
	4.22	Fork dimensions		s/ e/l	mm	40 x 100 x 1200	50 x 100 x 1250	50 x 100 x 1200	40 x 100 x 1200	50 x 100 x 1250	50 x 100 x 1200
	4.25	Width across forks		b5	mm	560					
	4.31	Ground clearance laden under mast		m1	mm	50					
4.35	Turning radius		Wa	mm	1643		1845				
Performance data	5.1	Travel speed laden/unladen		km/h	10 / 10						
	5.2	Lift speed laden/unladen		m/s	0.25 / 0.25						
	5.3	Lowering speed laden/unladen		m/s	0.3 / 0.25						
	5.10	Service brake			regenerative						
	5.11	Parking brake			Electric sprung-loaded						

Electric motor/electronics	6.1	Drive motor, performance S2 60 min	kW	3	6
	6.2	Lift motor, performance with S3	kW	8	
	6.3	Battery according to DIN 43531/35/36		6 PzS 930	8 PzS 1240
	6.4	Battery voltage/nominal capacity	V / Ah	24 / 930	24 / 1240
	6.5	Battery weight	kg	700	910
Other	8.1	Type of drive control		AC drive control system	
	10.5	Steering version		electric	
	10.7	Sound pressure level according to EN12053	dB (A)	60	65

- This data sheet according to VDI guideline 2198 only states the technical values of the standard truck. Different tyres, other masts, additional equipment etc. may result in different values.

5.1. With drivePLUS performance module

The German production facilities in
Norderstedt, Moosburg and Landsberg are
certified as well as our Genuine Parts
Center in Kaltenkirchen.

ISO 9001
ISO 14001

Jungheinrich fork lift trucks meet European
safety requirements.



 **JUNGHEINRICH**

The logo features a red upward-pointing arrow integrated into the letter 'J' of the word 'JUNGHEINRICH', which is written in a bold, black, sans-serif font.