



Elektrische vierwielheftruck

EFG 316ki-320i

Hefhoogte: 2020-7000 mm / Draagvermogen: 1600-2000 kg



EFG 316ki-320i

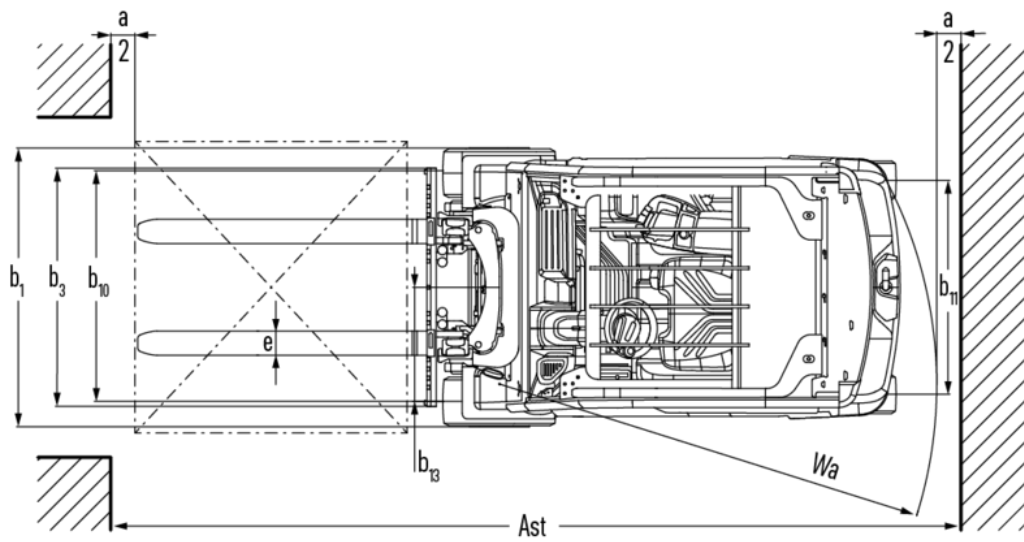
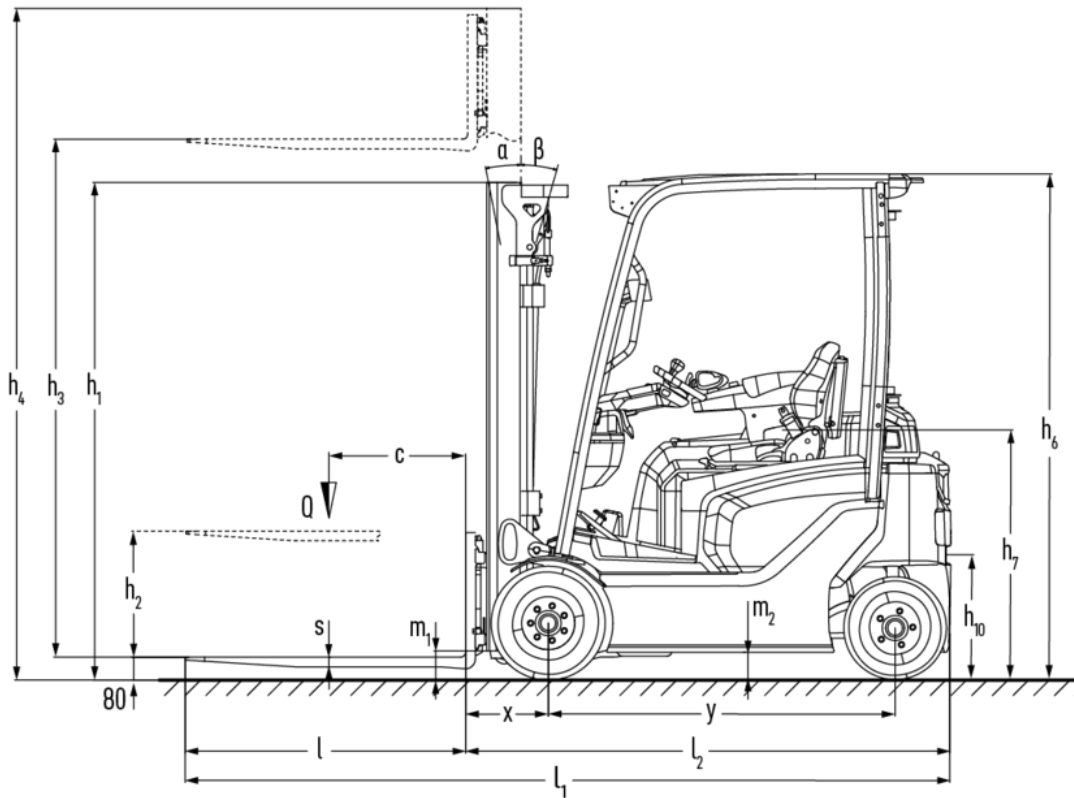

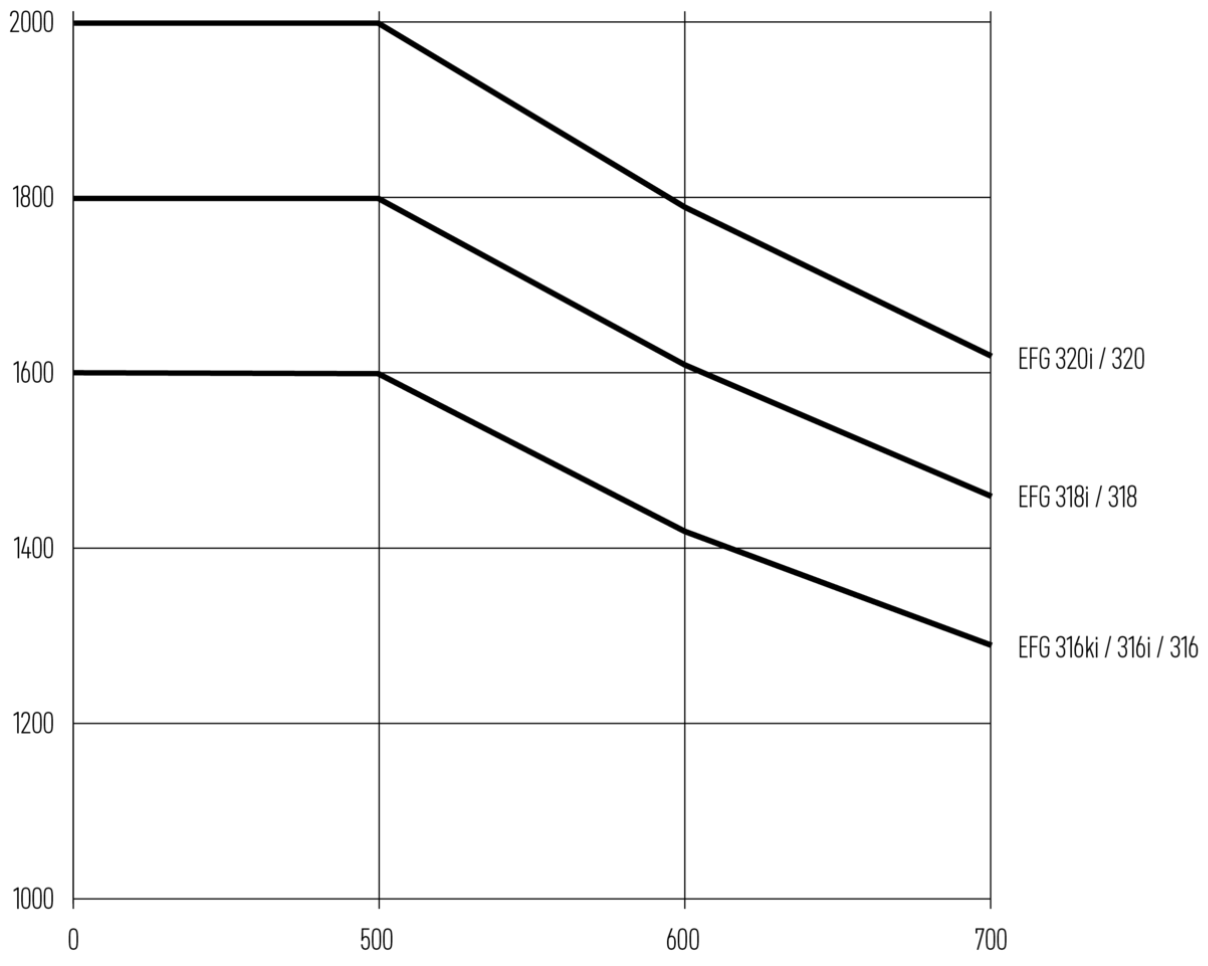

EFG 316ki–320i

EFG 316ki, EFG 316i	Heffing (h3)	Ingeschoven masthoogte (h1)	Vrije heffing (h2)	Uitgeschoven masthoogte (h4)	Neiging mast voorover/achterover
Drievoudige mast DZ	4250 mm	1975 mm	1385 mm	4840 mm	
	4400 mm	2025 mm	1435 mm	4990 mm	
	4640 mm	2105 mm	1515 mm	5230 mm	
	4700 mm	2125 mm	1535 mm	5290 mm	
	4800 mm	2165 mm	1575 mm	5390 mm	
	5000 mm	2235 mm	1645 mm	5590 mm	
	5500 mm	2415 mm	1825 mm	6090 mm	
	6000 mm	2585 mm	1995 mm	6590 mm	
	6500 mm	2765 mm	2175 mm	7090 mm	
	7000 mm	2935 mm	2345 mm	7590 mm	
Tweevoudige mast ZT	3000 mm	2060 mm	150 mm	3590 mm	7 / 7 °
	3100 mm	2110 mm	150 mm	3690 mm	
	3300 mm	2210 mm	150 mm	3890 mm	
	3500 mm	2310 mm	150 mm	4090 mm	
	3700 mm	2410 mm	150 mm	4290 mm	
	4000 mm	2560 mm	150 mm	4590 mm	
	4500 mm	2810 mm	150 mm	5090 mm	
Tweevoudige mast ZZ	2900 mm	1965 mm	1375 mm	3490 mm	
	3100 mm	2065 mm	1475 mm	3690 mm	
	3180 mm	2105 mm	1515 mm	3770 mm	
	3300 mm	2165 mm	1575 mm	3890 mm	
	3500 mm	2265 mm	1675 mm	4090 mm	
	3700 mm	2365 mm	1775 mm	4290 mm	
	4000 mm	2515 mm	1925 mm	4590 mm	
EFG 318i, EFG 320i	Heffing (h3)	Ingeschoven masthoogte (h1)	Vrije heffing (h2)	Uitgeschoven masthoogte (h4)	Neiging mast voorover/achterover
Drievoudige mast DZ	4250 mm	1982 mm	1340 mm	4892 mm	
	4400 mm	2032 mm	1390 mm	5042 mm	
	4640 mm	2112 mm	1470 mm	5282 mm	
	4700 mm	2132 mm	1490 mm	5342 mm	
	4800 mm	2172 mm	1530 mm	5442 mm	
	5000 mm	2242 mm	1600 mm	5642 mm	
	5500 mm	2422 mm	1780 mm	6142 mm	
	6000 mm	2592 mm	1950 mm	6642 mm	
	6500 mm	2772 mm	2130 mm	7142 mm	
	7000 mm	2942 mm	2300 mm	7642 mm	
Tweevoudige mast ZT	2020 mm	1577 mm	150 mm	2632 mm	
	3000 mm	2067 mm	150 mm	3612 mm	
	3100 mm	2117 mm	150 mm	3712 mm	
	3300 mm	2217 mm	150 mm	3912 mm	

	3500 mm	2317 mm	150 mm	4112 mm	
	3700 mm	2417 mm	150 mm	4312 mm	
	4000 mm	2567 mm	150 mm	4612 mm	
	4500 mm	2817 mm	150 mm	5112 mm	
Tweevoudige mast ZZ	2900 mm	1972 mm	1330 mm	3542 mm	
	3100 mm	2072 mm	1430 mm	3742 mm	
	3180 mm	2112 mm	1470 mm	3822 mm	
	3300 mm	2172 mm	1530 mm	3942 mm	
	3500 mm	2272 mm	1630 mm	4142 mm	
	3700 mm	2372 mm	1730 mm	4342 mm	
	4000 mm	2522 mm	1880 mm	4642 mm	

VDI-tabel

Kenmerken	1.1	Fabrikant (korte naam)		Jungheinrich			
	1.2	Typeaanduiding fabrikant		EFG 316ki	EFG 316i	EFG 318i	EFG 320i
	1.3	Aandrijving		Elektrisch			
	1.4	Bediening		Stoel			
	1.5	Draagvermogen/last	Q kg	1600		1800	2000
	1.6	Lastzwaartepuntafstand	c mm	500			
	1.8	Lastafstand	x mm	339		359	
	1.9	Wielbasis	y mm	1314	1422		1530
	Gewichten	2.1.1	Eigen gewicht (incl. accu)	kg	2799	2645	2981
2.2		Aslast met last voor/achter	kg	3809 / 590	3735 / 510	4205 / 576	4505 / 580
2.3		Aslast onbelast voor/achter	kg	1187 / 1612	1191 / 1454	1317 / 1664	1382 / 1703
Wielen/chassis	3.1	Banden		SuperElastik (SE)			
	3.2	Bandenmaat, voor		180 / 70-8		200 / 50-10	
	3.3	Bandenmaat, achter		150 / 75-8			
	3.5	Wielen, aantal voor/achter (x = aangedreven)		2x/2			
	3.6	Spoorbreedte, voor	b10 mm	929		939	
	3.7	Spoorbreedte, achter	b11 mm	880			
	Afmetingen	4.1	Neiging mast voorover/achterover	a/B °	7 / 6		
4.2		Ingeschoven masthoogte (h1)	h1 mm	2210		2217	
4.3		Vrije heffing (h2)	h2 mm	150			
4.4		Heffing (h3)	h3 mm	3300			
4.5		Uitgeschoven masthoogte (h4)	h4 mm	3890		3912	
4.7		Hoogte beschermend dak (cabine)	h6 mm	2070			
4.8		Zithoogte / stahoogte	h7 mm	1030			
4.12		Koppelingshoogte	h10 mm	490			
4.19		Totale lengte	l1 mm	3031	3139	3159	3267
4.20		Lengte inclusief vorkrug	l2 mm	1881	1989	2009	2117
4.21.1		Totale breedte	b1 mm	1085		1145	
4.22		Vorkafmetingen	s/e/l mm	40 x 80 x 1150			40 x 100 x 1150
4.23		Vorkenbord aansluitklasse		2A			
4.24		Breedte vorkenbord	b3 mm	980			
4.31		Bodemvrijheid met last onder hefmast	m1 mm	97		105	
4.32		Bodemvrijheid midden wielbasis	m2 mm	100			
4.34.1		Werkbreedte (pallet 1000 x 1200 dwars)	Ast mm	3217	3320	3339	3443
4.34.2	Werkbreedte (pallet 800x1200 longitudinaal)	Ast mm	3343	3447	3467	3570	
4.35	Draaicirkel	Wa mm	1558	1662		1766	
4.36	Kleinste draaipuntafstand	b13 mm	21	22		23	

Prestaties	5.1	Rijsnelheid met last/onbelast	km/u	17 / 17		
	5.2	Hefsnelheid met last/onbelast	m/s	0,55 / 0,74	0,47 / 0,63	0,44 / 0,63
	5.3	Daalsnelheid met last/onbelast	m/s	0,55 / 0,55	0,52 / 0,55	0,55 / 0,52
	5.9	Acceleratietijd met last/onbelast	s	5,5 / 5,1		5,6 / 5,1
	5.10	Rem		Wrijvingsrem (mechanisch bediend)		
E-motor/elektronica	6.1	Rijmotor, vermogen S2 60 min	kW	5,5		
	6.1.1	2. Rijmotor, vermogen S2 60 min	kW	5,5		
	6.2	Hefmotor, vermogen bij S3	kW	12		
	6.3	Accu volgens DIN 43531/35/36		Jungheinrich Li-ion		
	6.4	Accuspanning/nominaal vermogen	V / Ah	51,2 / 456	51,2 / 684	
	6.5	Accugewicht	kg	150	285	
	6.6.1	Energieverbruik volgens EN-cyclus	kWh/u	4,3	4,6	4,8
	6.6.2	CO2-equivalent volgens EN ISO 23308	kg/h0	2,32	2,49	2,59
	6.7	Omslag	t/h	117	127,8	140
6.8	Omzettefficiëntie volgens VDI 2198	t/kWh	21,2	22,2	23,7	
Overig	8.1	Type rijregeling		Impuls/AC		
	10.1	Werkdruk voor aanbouwapparaat	bar	230		
	10.2	Oliestroom voor aanbouwapparatuur	l/min	27,5		
	10.7	Geluidsniveau volgens EN12053	dB (A)	63		

- Dit typeblad volgens VDI-richtlijn 2198 noemt alleen de technische waarden van de standaardmachine. Afwijkende banden, andere hefmasten, extra systemen etc. kunnen resulteren in andere waarden.

De Duitse fabrieken in Norderstedt,
Moosburg en Landsberg zijn gecertificeerd,
evenals ons onderdelenmagazijn in
Kaltenkirchen. ISO 9001
ISO 14001

Jungheinrich intern transport materieel
voldoet aan de Europese
veiligheidsvoorschriften. 

**JUNGHEINRICH**