



Hand pallet truck

AM l20/l20p

Lift height: 120 mm / Load capacity: 2000 kg

JUNGHEINRICH

AM I20/I20p

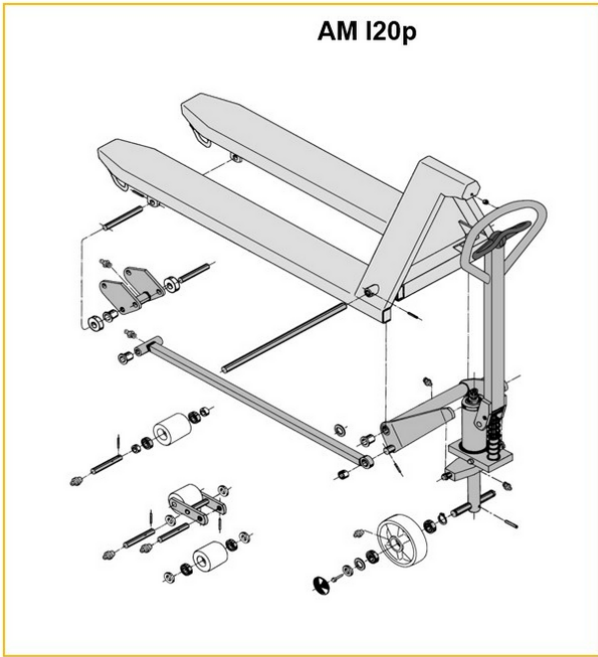
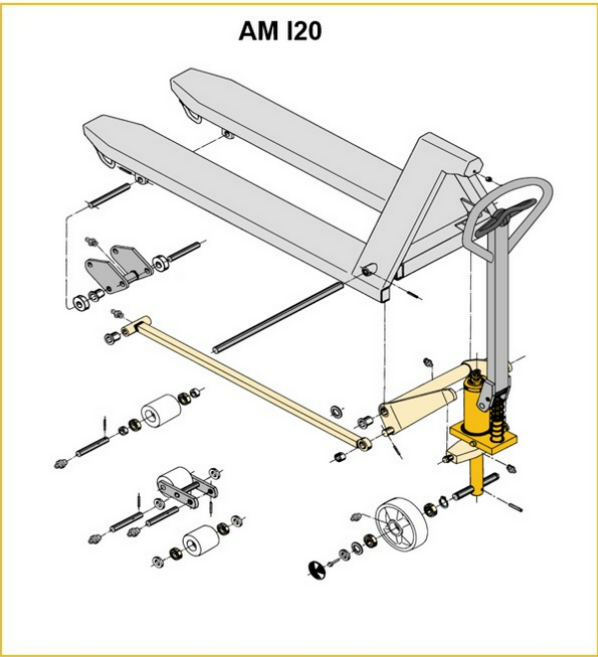

Inox AISI 316 (V4A)
Inox AISI 303/304 (V2A)

Feuerverzinkt
Verzinkt und gelb chromatiert



AM I20



AM 120p

VDI table

Characteristic	1.1	Manufacturer (abbreviated description)		Other (OEM)							
	1.2	Manufacturer's type designation		AM 120p							
	1.3	Drive type		Manual							
	1.4	Operation		Manual							
	1.5	Load capacity/load	Q kg	2000							
	1.6	Load centre distance	c mm	610				570			
	1.9	Wheelbase	y mm	1245				1165			
Weights	2.1	Netto weight	kg	81		78			75		
	2.1.1	Service weight (incl. battery)	kg	81		78			64		
Wheels/chassis	3.1	Tyres		V-BV	N-BN	V-GV	N-GN	V-BV	N-BN	C-GV	N-GN
	3.2	Tyre size, front		Ø 200x50							
	3.3	Tyre size, rear		Ø 80x70	Ø 80x65	Ø 80x90		Ø 80x70	Ø 80x65	Ø 80x90	
	3.5	Wheels, number front/back (x=driven)		2/2							
	3.6	Tread width, front	b10 mm	120							
	3.7	Tread width, rear	b11 mm	520							
	Basic dimensions	4.4	Lift (h3)	h3 mm	120						
4.9		Height of tiller handle in drive position min./max.	h14 mm	1170							
4.14		Stand height, elevated	h12 mm	205							
4.15		Height, lowered	h13 mm	85							
4.19		Total length	l1 mm	1555				1475			
4.21.1		total width	b1 mm	680							
4.22		Fork dimensions	s/ e/l mm	51 x 160 x 1220				51 x 160 x 1140			
4.25		Width across forks	b5 mm	680							
4.32		Ground clearance centre of wheelbase	m2 mm	34							
4.34.1		Aisle width (pallet 1000×1200 sideways)	Ast mm	1610							
4.34.2		Aisle width (pallet 800x1200 length)	Ast mm	1830				1810			
4.35	Turning radius	Wa mm	1410				1330				
Performance data	5.3	Lowering speed laden/unladen	m/s	0.1 / 0.05							
- This data sheet according to VDI guideline 2198 only states the technical values of the standard truck. Different tyres, other masts, additional equipment etc. may result in different values.											

Characteristic	1.1	Manufacturer (abbreviated description)		Other (OEM)							
	1.2	Manufacturer's type designation		AM I20p							
	1.3	Drive type		Manual							
	1.4	Operation		Manual							
	1.5	Load capacity/load	Q kg	2000							
	1.6	Load centre distance	c mm	485				405			
	1.9	Wheelbase	y mm	995				835			
Weights	2.1	Netto weight	kg	72		69				65	
	2.1.1	Service weight (incl. battery)	kg	72		69		66		64	
Wheels/chassis	3.1	Tyres		V-BV	N-BN	V-GV	N-GN	V-BV	N-BN	V-GV	N-GN
	3.2	Tyre size, front		Ø 200x50							
	3.3	Tyre size, rear		Ø 80x70	Ø 80x65	Ø 80x90		Ø 80x70	Ø 80x65	Ø 80x90	
	3.5	Wheels, number front/back (x=driven)		2/2							
	3.6	Tread width, front	b10 mm	120							
	3.7	Tread width, rear	b11 mm	520							
	Basic dimensions	4.4	Lift (h3)	h3 mm	120						
4.9		Height of tiller handle in drive position min./max.	h14 mm	1170							
4.14		Stand height, elevated	h12 mm	205							
4.15		Height, lowered	h13 mm	85							
4.19		Total length	l1 mm	1305				1145			
4.21.1		total width	b1 mm	680							
4.22		Fork dimensions	s/ e/l mm	51 x 160 x 970				51 x 160 x 810			
4.25		Width across forks	b5 mm	680							
4.32		Ground clearance centre of wheelbase	m2 mm	34							
4.34.1		Aisle width (pallet 1000x1200 sideways)	Ast mm	1610							
4.34.2	Aisle width (pallet 800x1200 length)	Ast mm	1810								
4.35	Turning radius	Wa mm	1160				1000				
Performance data	5.3	Lowering speed laden/unladen	m/s	0.1 / 0.05							
<p>- This data sheet according to VDI guideline 2198 only states the technical values of the standard truck. Different tyres, other masts, additional equipment etc. may result in different values.</p>											

Characteristic	1.1	Manufacturer (abbreviated description)		Other (OEM)								
	1.2	Manufacturer's type designation		AM I20p								
	1.3	Drive type		Manual								
	1.4	Operation		Manual								
	1.5	Load capacity/load	Q kg	2000								
	1.6	Load centre distance	c mm	610				570				
	1.9	Wheelbase	y mm	1245				1165				
Weights	2.1	Netto weight	kg	75	72				69			
	2.1.1	Service weight (incl. battery)	kg	75	72		64					
	2.2	Axle load laden front/rear	-	- / -						636 / 1432		
	2.3	Axle load unladen front/rear	-	- / -						21 / 47		
Wheels/chassis	3.1	Tyres		V-BV	N-BN	V-GV	N-GN	V-BV	N-BN	V-GV	N-GN	
	3.2	Tyre size, front		Ø 200x50								
	3.3	Tyre size, rear		Ø 80x70	Ø 80x65	Ø 80x90		Ø 80x70	Ø 80x65	Ø 80x90		
	3.5	Wheels, number front/back (x=driven)		2/2								
	3.6	Tread width, front	b10 mm	120								
	3.7	Tread width, rear	b11 mm	360								
	Basic dimensions	4.4	Lift (h3)	h3 mm	120							
4.9		Height of tiller handle in drive position min./max.	h14 mm	1170						1220 / 1170		
4.14		Stand height, elevated	h12 mm	205								
4.15		Height, lowered	h13 mm	85								
4.19		Total length	l1 mm	1555				1475				
4.20		Length including fork shank	l2 mm	-						340		
4.21.1		total width	b1 mm	520								
4.22		Fork dimensions	s/ e/l mm	51 x 160 x 1220				51 x 160 x 1140				
4.25		Width across forks	b5 mm	520								
4.32		Ground clearance centre of wheelbase	m2 mm	34								
4.34.1		Aisle width (pallet 1000×1200 sideways)	Ast mm	1610								
4.34.2	Aisle width (pallet 800x1200 length)	Ast mm	1830				1810					
4.35	Turning radius	Wa mm	1410				1330					
Performance data	5.3	Lowering speed laden/unladen	m/s	0.1 / 0.05								

- This data sheet according to VDI guideline 2198 only states the technical values of the standard truck. Different tyres, other masts, additional equipment etc. may result in different values.

Characteristic	1.1	Manufacturer (abbreviated description)		Other (OEM)								
	1.2	Manufacturer's type designation		AM I20p								
	1.3	Drive type		Manual								
	1.4	Operation		Manual								
	1.5	Load capacity/load	Q kg	2000								
	1.6	Load centre distance	c mm	485				405				
	1.9	Wheelbase	y mm	995				835				
Weights	2.1	Netto weight	kg	66		63				59		
	2.1.1	Service weight (incl. battery)	kg	66		63				64		
Wheels/chassis	3.1	Tyres		V-BV	N-BN	V-GV	N-GN	V-BV	N-BN	V-GV	N-GN	
	3.2	Tyre size, front		Ø 200x50								
	3.3	Tyre size, rear		Ø 80x70	Ø 80x65	Ø 80x90		Ø 80x70	Ø 80x65	Ø 80x90		
	3.5	Wheels, number front/back (x=driven)		2/2								
	3.6	Tread width, front	b10 mm	120								
	3.7	Tread width, rear	b11 mm	360				335				360
	Basic dimensions	4.4	Lift (h3)	h3 mm	120							
4.9		Height of tiller handle in drive position min./max.	h14 mm	1170								
4.14		Stand height, elevated	h12 mm	205								
4.15		Height, lowered	h13 mm	85								
4.19		Total length	l1 mm	1305				1145				
4.21.1		total width	b1 mm	520								
4.22		Fork dimensions	s/ e/l mm	51 x 160 x 970				51 x 160 x 810				
4.25		Width across forks	b5 mm	520								
4.32		Ground clearance centre of wheelbase	m2 mm	34								
4.34.1		Aisle width (pallet 1000x1200 sideways)	Ast mm	1610								
4.34.2	Aisle width (pallet 800x1200 length)	Ast mm	1810									
4.35	Turning radius	Wa mm	1160				1000					
Performance data	5.3	Lowering speed laden/unladen	m/s	0.1 / 0.05								

- This data sheet according to VDI guideline 2198 only states the technical values of the standard truck. Different tyres, other masts, additional equipment etc. may result in different values.

Characteristic	1.1	Manufacturer (abbreviated description)		Other (OEM)							
	1.2	Manufacturer's type designation		AM I20							
	1.3	Drive type		Manual							
	1.4	Operation		Manual							
	1.5	Load capacity/load	Q kg	2000							
	1.6	Load centre distance	c mm	405				485			
	1.9	Wheelbase	y mm	835				995			
Weights	2.1	Netto weight	kg	59		63				66	
	2.1.1	Service weight (incl. battery)	kg	59		63				66	
Wheels/chassis	3.1	Tyres		N-GN	V-GV	N-BN	V-BV	N-GN	V-GV	N-BN	V-BV
	3.2	Tyre size, front		Ø 200x50							
	3.3	Tyre size, rear		Ø 80x90		Ø 80x65	Ø 80x70	Ø 80x90		Ø 80x65	Ø 80x70
	3.5	Wheels, number front/back (x=driven)		2/2							
	3.6	Tread width, front	b10 mm	120							
	3.7	Tread width, rear	b11 mm	360							
	Basic dimensions	4.4	Lift (h3)	h3 mm	120						
4.9		Height of tiller handle in drive position min./max.	h14 mm	1170							
4.14		Stand height, elevated	h12 mm	200							
4.15		Height, lowered	h13 mm	85							
4.19		Total length	l1 mm	1145				1305			
4.21.1		total width	b1 mm	520							
4.22		Fork dimensions	s/ e/l mm	51 x 160 x 810				51 x 160 x 970			
4.25		Width across forks	b5 mm	520							
4.32		Ground clearance centre of wheelbase	m2 mm	34		38					
4.34.1		Aisle width (pallet 1000x1200 sideways)	Ast mm	1610							
4.34.2	Aisle width (pallet 800x1200 length)	Ast mm	1810								
4.35	Turning radius	Wa mm	1000				1160				
Performance data	5.3	Lowering speed laden/unladen	m/s	0.1 / 0.05							
<p>- This data sheet according to VDI guideline 2198 only states the technical values of the standard truck. Different tyres, other masts, additional equipment etc. may result in different values.</p>											

Characteristic	1.1	Manufacturer (abbreviated description)		Other (OEM)							
	1.2	Manufacturer's type designation		AM I20							
	1.3	Drive type		Manual							
	1.4	Operation		Manual							
	1.5	Load capacity/load	Q kg	2000							
	1.6	Load centre distance	c mm	570				610			
	1.9	Wheelbase	y mm	1165				1245			
Weights	2.1	Netto weight	kg	69		72		75			
	2.1.1	Service weight (incl. battery)	kg	69		72		75			
	2.2	Axle load laden front/rear	kg	636 / 1432		- / -					
	2.3	Axle load unladen front/rear	kg	21 / 47		- / -					
Wheels/chassis	3.1	Tyres		N-GN	V-GV	N-BN	V-BV	N-GN	V-GV	N-BN	V-BV
	3.2	Tyre size, front		Ø 200x50							
	3.3	Tyre size, rear		Ø 80x90		Ø 80x65	Ø 80x70	Ø 80x90		Ø 80x65	Ø 80x90
	3.5	Wheels, number front/back (x=driven)		2/2							
	3.6	Tread width, front	b10 mm	120							
	3.7	Tread width, rear	b11 mm	360							
	Basic dimensions	4.4	Lift (h3)	h3 mm	120						
4.9		Height of tiller handle in drive position min./max.	h14 mm	1170							
4.14		Stand height, elevated	h12 mm	200							
4.15		Height, lowered	h13 mm	85							
4.19		Total length	l1 mm	1475				1555			
4.20		Length including fork shank	l2 mm	340		-					
4.21.1		total width	b1 mm	520							
4.22		Fork dimensions	s/ e/l mm	51 x 160 x 1140				51 x 160 x 1220			
4.25		Width across forks	b5 mm	520							
4.32		Ground clearance centre of wheelbase	m2 mm	38							
4.34.1		Aisle width (pallet 1000×1200 sideways)	Ast mm	1610							
4.34.2	Aisle width (pallet 800x1200 length)	Ast mm	1810				1830				
4.35	Turning radius	Wa mm	1330				1410				
Performance data	5.3	Lowering speed laden/unladen	m/s	0.1 / 0.05							

- This data sheet according to VDI guideline 2198 only states the technical values of the standard truck. Different tyres, other masts, additional equipment etc. may result in different values.

Characteristic	1.1	Manufacturer (abbreviated description)		Other (OEM)							
	1.2	Manufacturer's type designation		AM I20							
	1.3	Drive type		Manual							
	1.4	Operation		Manual							
	1.5	Load capacity/load	Q kg	2000							
	1.6	Load centre distance	c mm	405				485			
	1.9	Wheelbase	y mm	835				995			
Weights	2.1	Netto weight	kg	65		69			72		
	2.1.1	Service weight (incl. battery)	kg	65		69			72		
Wheels/chassis	3.1	Tyres		N-GN	V-GV	V-BV	N-BN	N-GN	V-GV	N-BN	V-BV
	3.2	Tyre size, front		Ø 200x50							
	3.3	Tyre size, rear		Ø 80x90		Ø 80x70	Ø 80x65	Ø 80x90		Ø 80x65	Ø 80x70
	3.5	Wheels, number front/back (x=driven)		2/2							
	3.6	Tread width, front	b10 mm	120							
	3.7	Tread width, rear	b11 mm	520							
	Basic dimensions	4.4	Lift (h3)	h3 mm	120						
4.9		Height of tiller handle in drive position min./max.	h14 mm	1170							
4.14		Stand height, elevated	h12 mm	200							
4.15		Height, lowered	h13 mm	85							
4.19		Total length	l1 mm	1145				1305			
4.21.1		total width	b1 mm	680							
4.22		Fork dimensions	s/ e/l mm	51 x 160 x 810				51 x 160 x 970			
4.25		Width across forks	b5 mm	680							
4.32		Ground clearance centre of wheelbase	m2 mm	38							
4.34.1		Aisle width (pallet 1000x1200 sideways)	Ast mm	1610							
4.34.2	Aisle width (pallet 800x1200 length)	Ast mm	1810								
4.35	Turning radius	Wa mm	1000				1160				
Performance data	5.3	Lowering speed laden/unladen	m/s	0.1 / 0.05							

- This data sheet according to VDI guideline 2198 only states the technical values of the standard truck. Different tyres, other masts, additional equipment etc. may result in different values.

Characteristic	1.1	Manufacturer (abbreviated description)		Other (OEM)							
	1.2	Manufacturer's type designation		AM I20							
	1.3	Drive type		Manual							
	1.4	Operation		Manual							
	1.5	Load capacity/load	Q kg	2000							
	1.6	Load centre distance	c mm	570				610			
	1.9	Wheelbase	y mm	1165				1245			
Weights	2.1	Netto weight	kg	75		78				81	
	2.1.1	Service weight (incl. battery)	kg	75		78				81	
Wheels/chassis	3.1	Tyres		N-GN	V-GV	N-BN	V-BV	N-GN	V-GV	V-BV	N-BN
	3.2	Tyre size, front		Ø 200x50							
	3.3	Tyre size, rear		Ø 80x90		Ø 80x65	Ø 80x70	Ø 80x90			Ø 80x65
	3.5	Wheels, number front/back (x=driven)		2/2							
	3.6	Tread width, front	b10 mm	120							
	3.7	Tread width, rear	b11 mm	520							
	Basic dimensions	4.4	Lift (h3)	h3 mm	120						
4.9		Height of tiller handle in drive position min./max.	h14 mm	1170							
4.14		Stand height, elevated	h12 mm	200							
4.15		Height, lowered	h13 mm	85							
4.19		Total length	l1 mm	1475				1555			
4.21.1		total width	b1 mm	680							
4.22		Fork dimensions	s/ e/l mm	51 x 160 x 1140				51 x 160 x 1220			
4.25		Width across forks	b5 mm	680							
4.32		Ground clearance centre of wheelbase	m2 mm	38							
4.34.1		Aisle width (pallet 1000×1200 sideways)	Ast mm	1610							
4.34.2	Aisle width (pallet 800x1200 length)	Ast mm	1810				1830				
4.35	Turning radius	Wa mm	1330				1410				
Performance data	5.3	Lowering speed laden/unladen	m/s	0.1 / 0.05							

- This data sheet according to VDI guideline 2198 only states the technical values of the standard truck. Different tyres, other masts, additional equipment etc. may result in different values.

The German production facilities in
Norderstedt, Moosburg and Landsberg are
certified as well as our Genuine Parts
Center in Kaltenkirchen.

ISO 9001
ISO 14001

Jungheinrich fork lift trucks meet European
safety requirements.



 **JUNGHEINRICH**

The Jungheinrich logo, featuring a red upward-pointing arrow above the word 'JUNGHEINRICH' in a bold, black, sans-serif font.